

**HYUNDAI**  
POWER PRODUCTS

# PETROL WOOD CHIPPER HYCH6560

Instruction Manual



GENUINE PRODUCT OF  
HYUNDAI CORPORATION

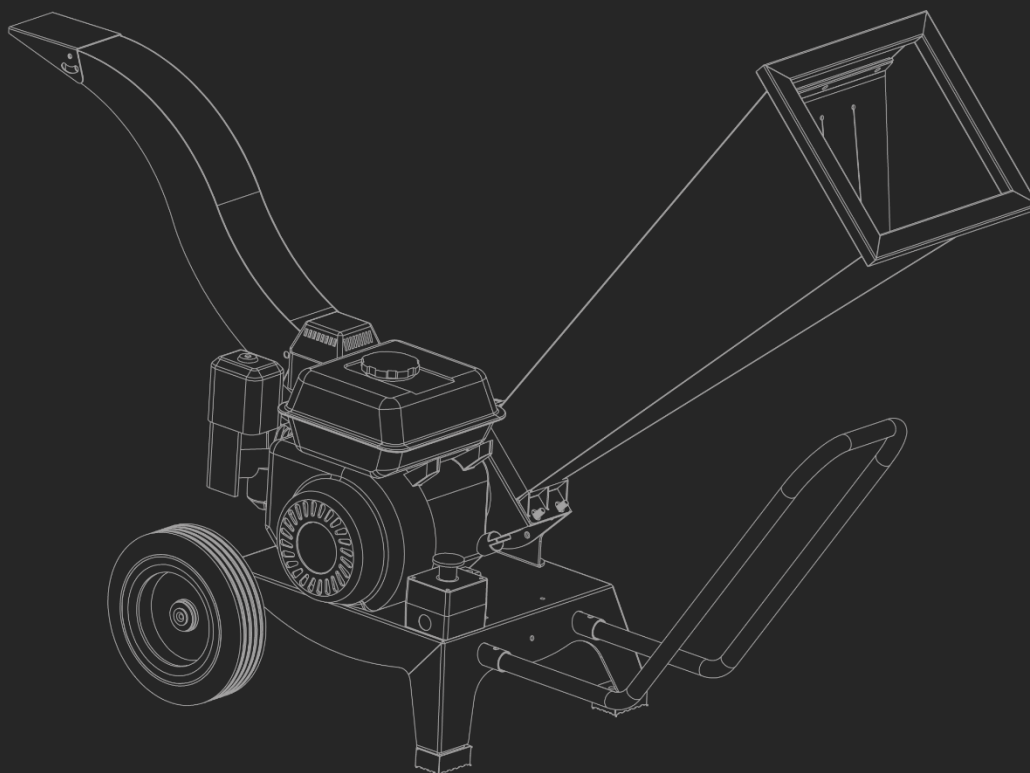

WARNING: Read the instructions carefully before use.

# INDEX

	<b>CONTENTS</b>	<b>PAGE NO.S</b>
1	SAFETY	3 - 8
2	PART LOCATIONS	9
3	ASSEMBLY	10 – 13
4	FUEL & OIL	14 – 15
5	STARTING PROCEDURE	15 – 17
6	STOPPING PROCEDURE	17 - 18
7	OPERATING INSTRUCTIONS	18 – 22
8	MAINTENANCE	23 – 26
9	STORAGE	27
10	TRANSPORT	27
11	TROUBLESHOOTING	28 - 29
12	SPECIFICATION	30
13	DECLARATION OF CONFORMITY	31
14	RECYCLING & PRODUCT DISPOSAL	32
15	CONTACT DETAILS	33
16	WARRANTY	33
17	MAUAL UPDATES	33

# 1. SAFETY

## 1.1 General Safety Notes.

1.2 The operator of the machine is responsible for, and has a duty of care in making sure that the machine is operated safely and in accordance with the instructions in this user manual. Keep the manual safe and pass it on if the machine is loaned or sold to another user.

1.3 Please note the following safety points.

1.4 The machine should never be left it in a condition which would allow an untrained or unauthorised person/s to operate this machine.

1.5 All due care and diligence should be taken by the operator for the safety of and with regard to those around whilst using the machine.

1.6 Some or all of the following - warning signs, symbols and/or PPE pictograms may appear throughout this manual. You **MUST** adhere to their warnings. Failure to do so may result in personal injury to yourself or those around you.



## DANGER

Indicates a hazard, which if not avoided, could result in serious injury or death.



## WARNING

Indicates a hazard, which if not avoided, could result in serious injury.



## CAUTION

Indicates a hazard, which if not avoided, might result in minor or moderate injury.



## NOTE

Indicates a situation that could easily result in equipment damage.

1.7 READ and keep the manual safe and pass it on if the machine is loaned or sold to another user.

1.8 You **MUST** fully understand all instructions to ensure you use and operate the machine safely.

1.9 Appropriate Personal Protective Equipment (PPE), **MUST** be worn at all times when operating or repairing the machine.



1.10 Carbon Monoxide (where applicable).

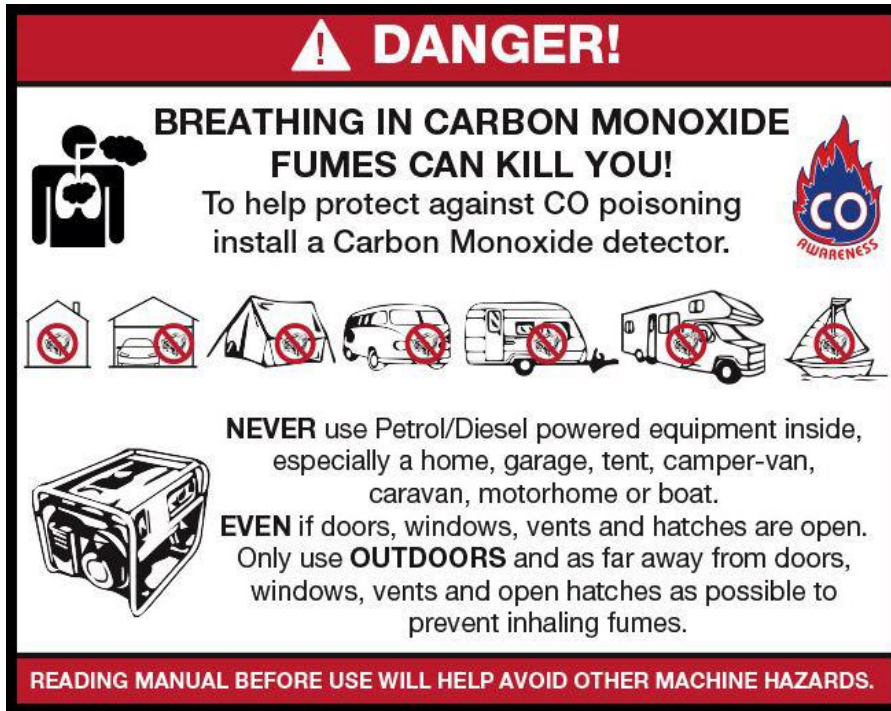

- 1.11 Carbon monoxide is a colourless and odourless gas. Inhaling this gas can cause death as well as serious long term health problems such as brain damage.
- 1.12 The symptoms of carbon monoxide poisoning can include but are not limited to the following;  
Headaches, dizziness, nausea, breathlessness, collapsing or loss of consciousness.
- 1.13 Carbon monoxide poisoning symptoms are similar to flue, food poisoning, viral infections and simply tiredness. It is quite common for people to mistake this very dangerous poisoning for something else.
- 1.14 To avoid carbon monoxide poisoning **DO NOT** use Petrol/Diesel powered equipment inside any of the following; Home, garage, tent, camper van, mobile home, caravan or boat. This is not exhaustive and if you are in any doubt contact your dealer.
- 1.15 If you think you have or someone around you has been affected by carbon monoxide poisoning;
- 1.16 Get them fresh air immediately, by leaving the affected area or by opening doors and windows. If safe and practical to do so make sure that the machine is turned off. **DO NOT** enter a room you suspect of having carbon monoxide present – instead call the emergency services.
- 1.17 Contact a Doctor immediately or go to Hospital – let them know that you suspect carbon monoxide poisoning.
- 1.18 **DO NOT** use in an enclosed area or moving vehicle.

1.20 **General Fuel Safety (where applicable).**



## CAUTION

**ALL FUELS ARE FLAMMABLE**

1.21 Fire Hazard – keep fuel away from all sources of ignition for example, heaters, lamps, direct sunlight and sparks from grinding or welding.



1.22 **DO NOT** carry out hot work on tanks that have contained fuel.

1.23 **ALWAYS** keep the work area clean and tidy.

1.24 **ALWAYS** clean up spills promptly using absorbent granules and a lidded bin.

1.25 **ALWAYS** dispose of waste fuel correctly.

1.30 **Fueling/De-Fueling (where applicable).**



## CAUTION

**ALL FUELS ARE FLAMMABLE**

1.31 **ALWAYS** fuel and defuel in a well-ventilated area outside of buildings.

1.32 **ALWAYS** wear correct, suitable and fit for purpose Personal Protective Equipment (PPE), suggested items are but not limited to safety gloves, overalls, eye protection and a respirator.



1.33 When fueling/de-fueling **ALWAYS** avoid inhaling fumes.

1.34 When de-fueling, **ALWAYS** use a proper fuel retriever.



1.35 **ALWAYS** carry fuel in the correct and clearly marked container.

1.40 **Electrical Safety (where applicable).**

1.41 Electricity can kill – **NEVER** work on **LIVE/ENERGISED** equipment.

1.42 Prior to carrying out any maintenance work you **MUST** identify electrical isolation methods and isolate all electrical supplies.

1.43 Prior to use and with all electrical supplies isolated, you **MUST** check all electrical cables, plugs and connectors for the following;

1.44 Are intact and have no signs of damage, to include but not limited to bare wires, chaffing, cuts and loose wiring.

1.45 If there are any signs of damage, the damaged item **MUST** be taken out of service until the damage has been repaired by an electrically competent person.

1.46 All trailing cables should be routed so as not to cause any kind of trip hazard.

1.47  **NEVER** work on or near electricity with wet hands, wet clothing and wet gloves.

### 1.50 **Batteries (where present).**

1.51 Batteries present a risk if they become damaged by the possible leaking of electrolyte. This electrolyte is an acid and can cause serious burn injuries. Care should be taken when working on or near them. **NOTE** the electrolyte may be in a liquid or gel form.

1.52 Should you come in to contact with electrolyte you should;

1.53 Remove all clothing contaminated with electrolyte. If you cannot remove then saturate them in water.

1.54 Get medical assistance as soon as possible. You must advise the medical staff of the type of acid.

1.55 Lead/acid battery = dilute sulphuric acid.

1.56 Nickel/cadmium = potassium hydroxide alkali electrolyte.

1.57 Use fresh running water to wash off excess electrolyte, continue this until medical assistance arrives. Make sure that you do not wash the electrolyte to another part of your body or face.

1.58 If electrolyte comes in to contact with Eyes the electrolyte needs to be immediately washed away with large amounts of water. Make sure that you do not wash the electrolyte to another part of your face or body.

1.59 Gasses from charging batteries are highly flammable and great care should be taken to charge in well ventilated areas.

1.59.1  There is an explosion risk if the battery terminals are short circuited, when connecting/disconnecting **ALWAYS** exercise great care so that the terminals or battery leads are **NOT** allowed to touch and cause a spark. **ALWAYS** use suitable insulated tools.

### 1.60 **Vibrations (where applicable).**

1.61 Prolonged use of hand held (operated) machines will cause the user to feel the effects of/from vibrations. These vibrations can lead to white finger (Raynaud's phenomenon) or carpal tunnel syndrome. This condition reduces the ability of the hand to feel and regulate temperature, causing numbness and heat sensations and may cause nerve damage and circulatory tissue death.

1.62 Not all factors that lead to white finger disease are known, but cold weather, smoking and other diseases that affect blood vessels and blood circulation as well as large and long-lasting impact of shocks are considered factors in the formation of white finger. Note the following to reduce the risk of white finger and carpal tunnel syndrome;

1.63 Wear gloves and keep your hands warm.

1.64 Take regular breaks.

- 1.65 All of the above precautions may help reduce the risk of white finger disease but not rule out the carpal tunnel syndrome. Long-term and regular users are therefore recommended to observe the condition of your hands and fingers. Seek medical attention immediately if any of the above symptoms should occur.
- 1.70 Noise (where applicable).**
- 1.71 The operating noise of the machine can damage your hearing. Wear hearing protection such as earplugs or ear defenders to protect your hearing. Long-term and regular users are advised to have hearing checked regularly. Be especially vigilant and cautious when hearing ear protection because your ability to hear alarm warnings will be reduced.
- 1.72 Noise emissions for this equipment is unavoidable. Carry out noisy work at approved times and for certain periods. Limit the working time to a minimum. For your personal protection and protection of people working nearby it is also advisable for them to wear hearing protection.
- 1.73  See Certificate of Conformity section for Outdoor Noise declaration of conformity.

## MACHINE SPECIFIC SAFETY

### **1.80 General Machine Safety.**

- 1.81 Read the owner's manual carefully to understand how to operate this machine properly.
- 1.82 You should **NEVER** use the machine when;
- 1.83 Wearing loose clothing, barefoot or sandals.
- 1.84 Under the influence of drink or drugs or as a result of having taken medication for cold or flu, or any other times when a possibility exists that your judgement might be impaired or that you might not be able to operate the machine properly and in a safe manner.
- 1.85 Suffering from exhaustion or lack of sleep.
- 1.86 When the ground is slippery or when other conditions exist which might make it not possible to maintain a steady posture.
- 1.87 At night, at times of heavy fog, or at any other times when your field of vision might be limited and it would be difficult to gain a clear view of the area.
- 1.88 During rain storms, lightning storms, at times of strong or gale force winds, or at any other times when the weather conditions might make it unsafe to use this product.
- 1.89 **NEVER** run the engine indoors. The exhaust gasses contain harmful carbon monoxide.
- 1.90 When using this machine for the first time and before actual work, you **MUST** learn how to handle the machine from an experienced or skilled person.

- 1.91 Limit the amount of time using the machine continuously to somewhere around 10 minutes per session and take 10 to 20 minutes of rest between sessions. Also try to keep the total amount of work in a single day limited to 2 hours or less.
- 1.92 **NEVER** allow children or anyone unable to fully understand the directions given in this manual to operate this product.
- 1.93 Make sure you keep this manual handy so you may refer to it whenever questions arise and ensure you pass this manual on if the machine is loaned or sold.
- 1.94 Correct Personal Protective Equipment (PPE) **MUST** be worn at all times when operating or repairing this machine. This should include but is not limited to;



- 1.95 **DO NOT** use this machine inside a confined space such as but not limited to a vehicle, house, garage, container, boat or building. Only use outside in a well ventilate area.
- 1.96 For air cooling a minimum of 1m is required all around the machine. Maximum ambient temperature 40 degrees Celsius.
- 1.97 Fire risk- Fuel can expand and overflow in a hot environment or moving vehicle. Explosion risk- LPG/ Petrol can leak and the vapour is heavier than air.
- 1.98 **NEVER** store in confined spaces especially in a boat where the vapour/has will accumulate in the hull and create a high risk of explosion.
- 1.99 Carbon monoxide poisoning risk- Never run an engine in a confined space or poorly ventilated area. Keep machine away from windows to prevent fumes entering the internal space.
- 1.99.1 Carbon monoxide is produced by the engine and contained in the exhaust fumes. You cannot see it or smell it and it can kill you in minutes. **NEVER** use inside a confined space with an exhaust extension. If the exhaust extension fails the escaping exhaust gases could kill you.

## 2. PART LOCATIONS

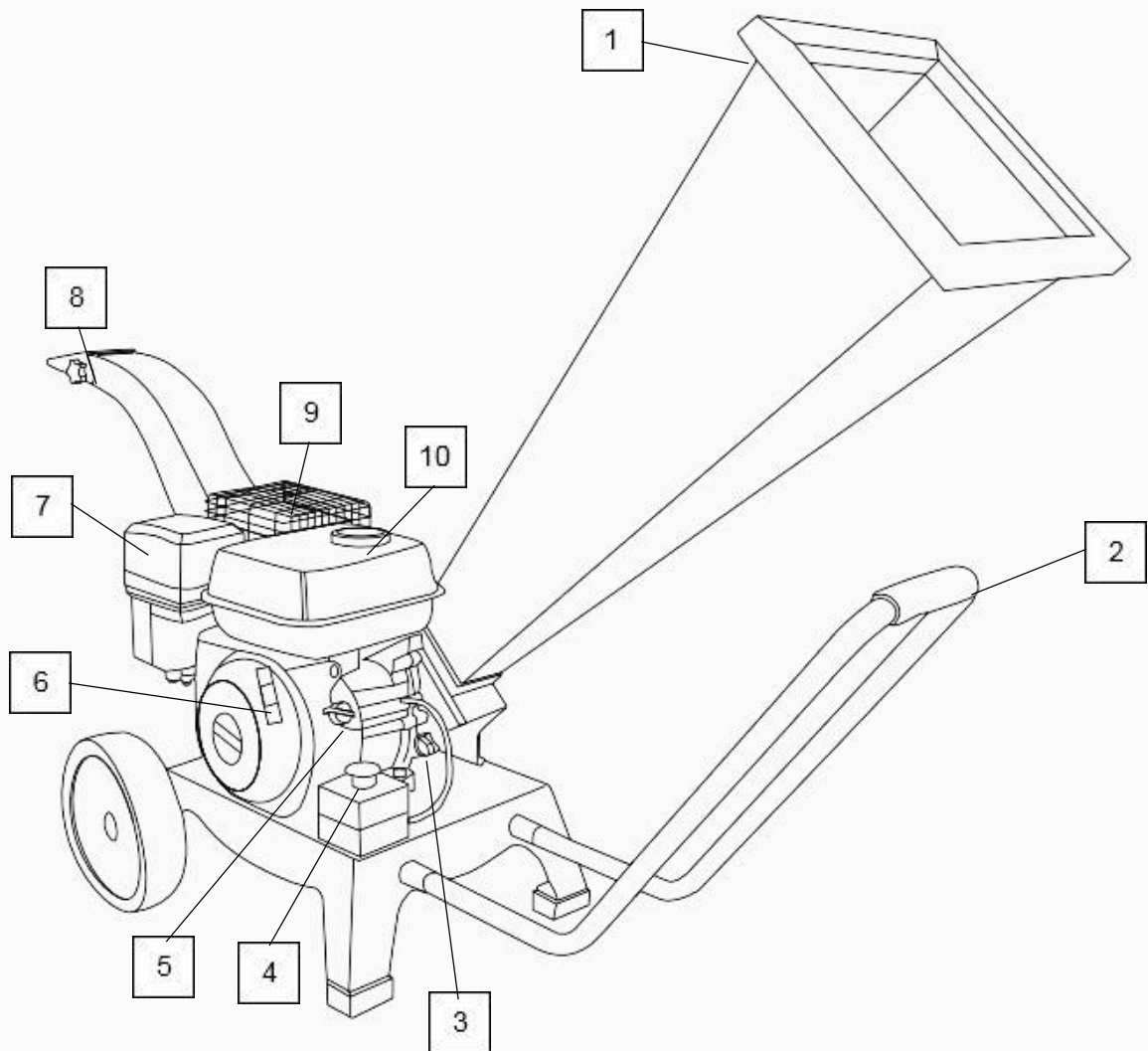

1	Feed Hopper	6	Recoil Start Handle
2	Handle	7	Air Filter
3	Oil Filler / Dipstick	8	Discharge Chute
4	Emergency Stop	9	Exhaust
5	Ignition Switch	10	Fuel Filler Cap

## 3. ASSEMBLY



### NOTE

Due to the weight of this machine, we recommend that you have assistance when assembling this machine.

Check all parts are supplied and in good condition before assembly.

- 3.0 Place the main chassis on a solid work surface.
- 3.1 Slide the wheels on to the axle.
- 3.2 Place a flat washer over the axle and up against the wheel face, then secure in place with a spring washer and 10mm bolt.

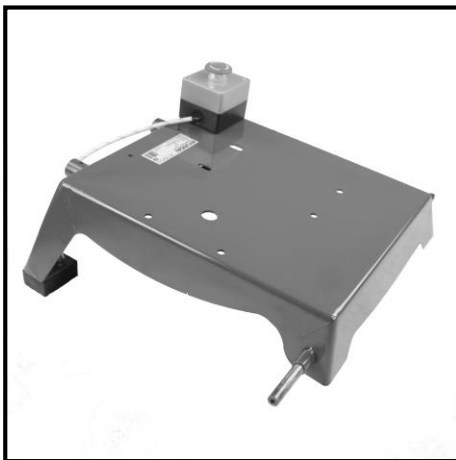

- 3.3 Align the two mounting points on the side of the main chassis with the two mounting points on the tab on the side of the engine and then place the engine on to the chassis ensuring these mounting points line up.

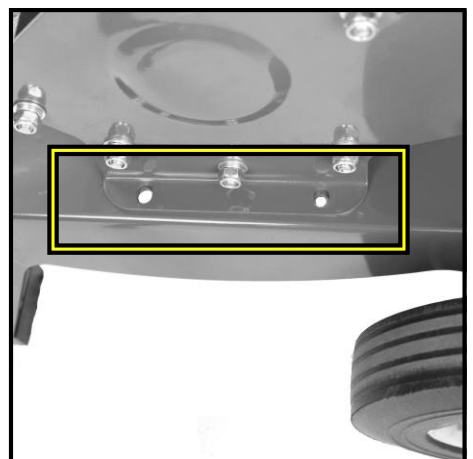
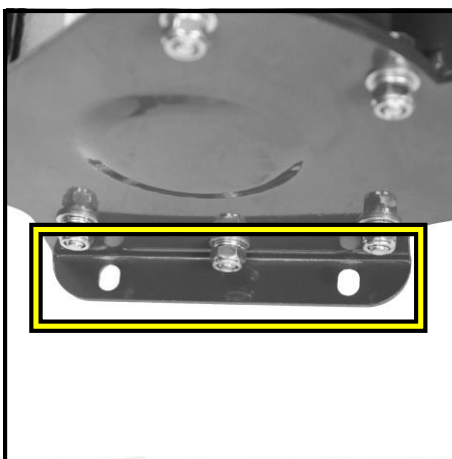
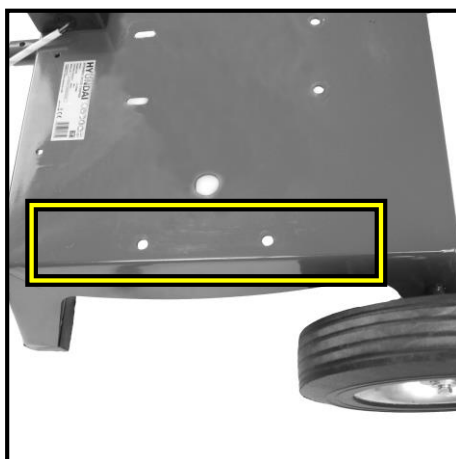

- 3.4 Put flat washers on the two shorter 13mm bolts and pass these through the aligned mounting holes, loosely secure underneath with a flat washer, spring washer and 13mm nut.
- 3.5 Complete the same process with the four remaining longer 13mm bolts to the two mounting positions at the front and rear of the engine.
- 3.6 Once all 6 mounting bolts are in place, ensure the engine is sitting square on the chassis and then tighten securely.

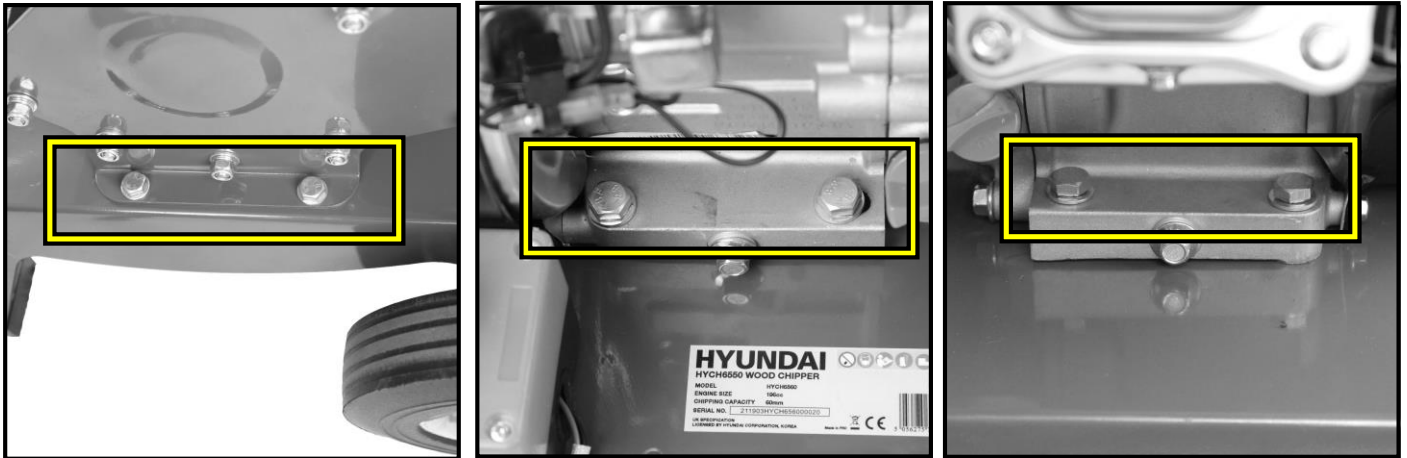

- 3.7 Locate the four feed hopper mounting studs on the engine assembly above and below the cutting blade.
- 3.8 Mount the feed hopper on to the studs ensuring the feed hopper is the correct way up.
- 3.9 Secure in place with four flat washers, spring washers and 13mm nuts.

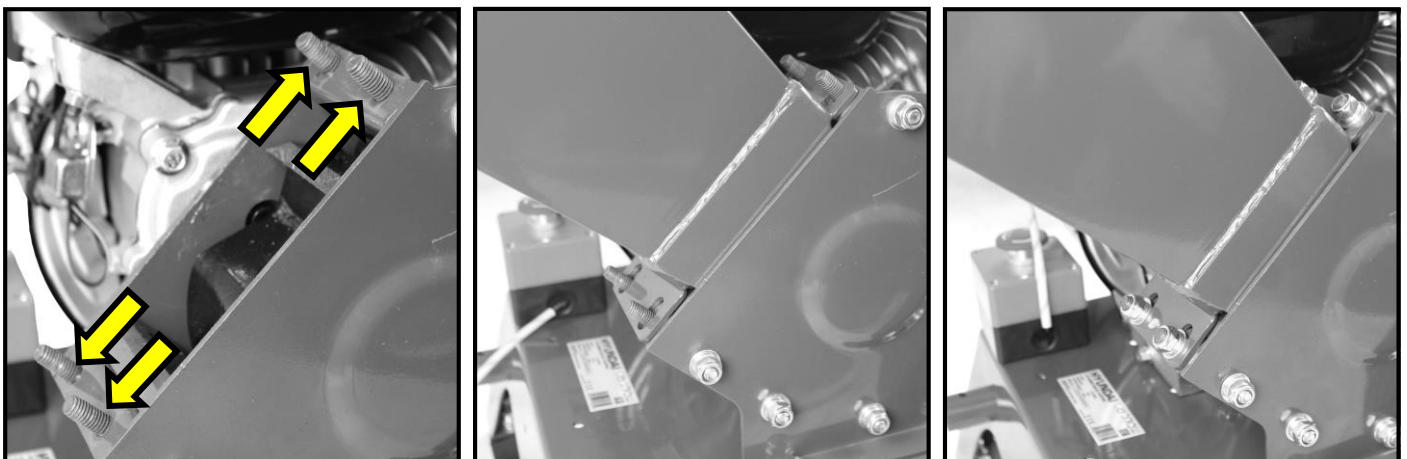

- 3.10 Locate the rear discharge chute mounting point at the back of the machine.
- 3.11 Slide the two cut outs on the discharge chute over the two studs and loosely secure in place with a flat washer, spring washer and 13mm nuts.
- 3.12 Place a spring washer and flat washer on to the 13mm bolt and screw in to the locating hole on the side of the rear discharge chute. Then tighten all the nuts securely.

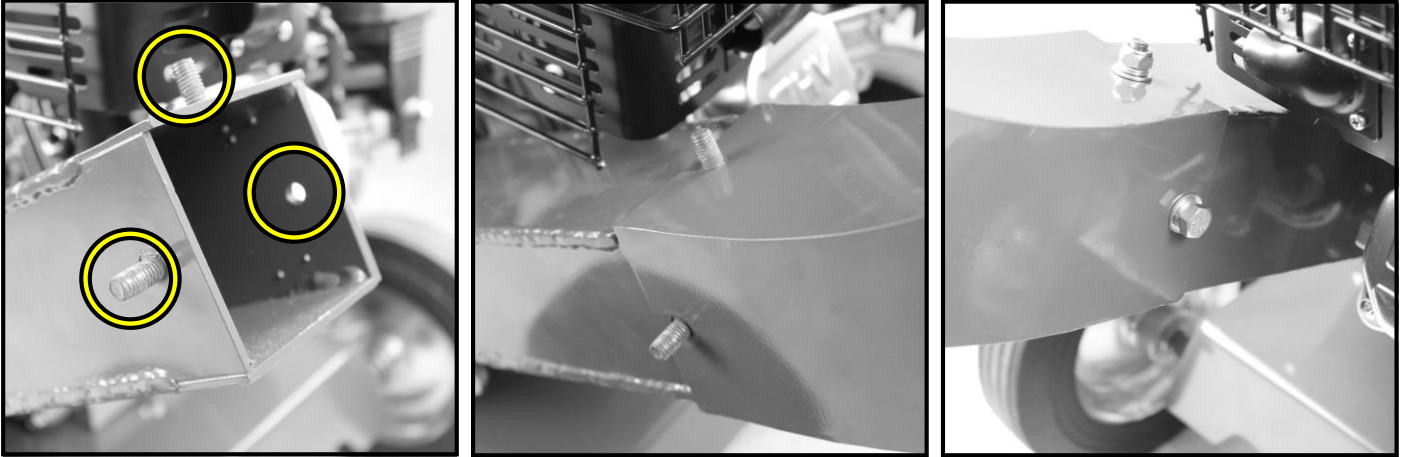

- 3.13 Slide the front handle into the mounting point at the front of the machine until the holes in the handle, line up with the holes in the mounting point.
- 3.14 Secure in place with the 10mm bolts.

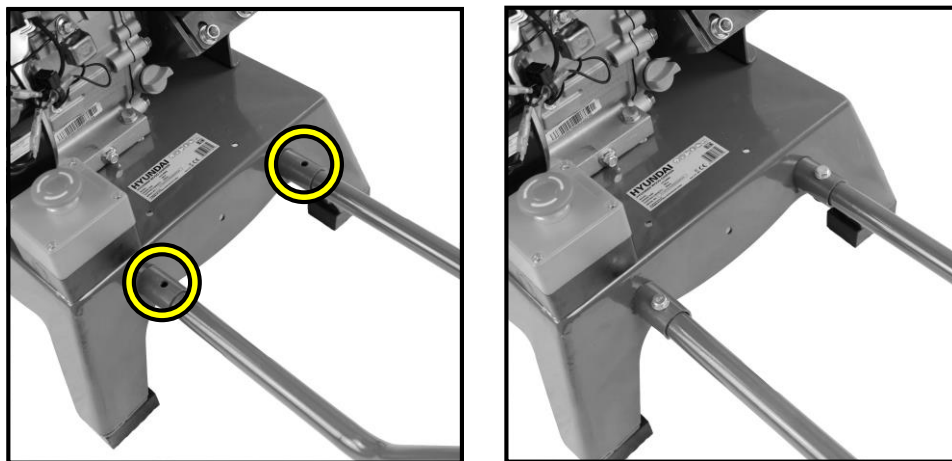

- 3.15 Connect the emergency stop button to the engine.
- 3.16 Connect the earth ring of the emergency stop button to a suitable location on the engine or frame.  
This will require removing a nut from a non-critical component, sliding the ring on to the thread and reinstalling the nut.  
This must be bare metal and not painted otherwise the emergency stop button will not operate correctly.

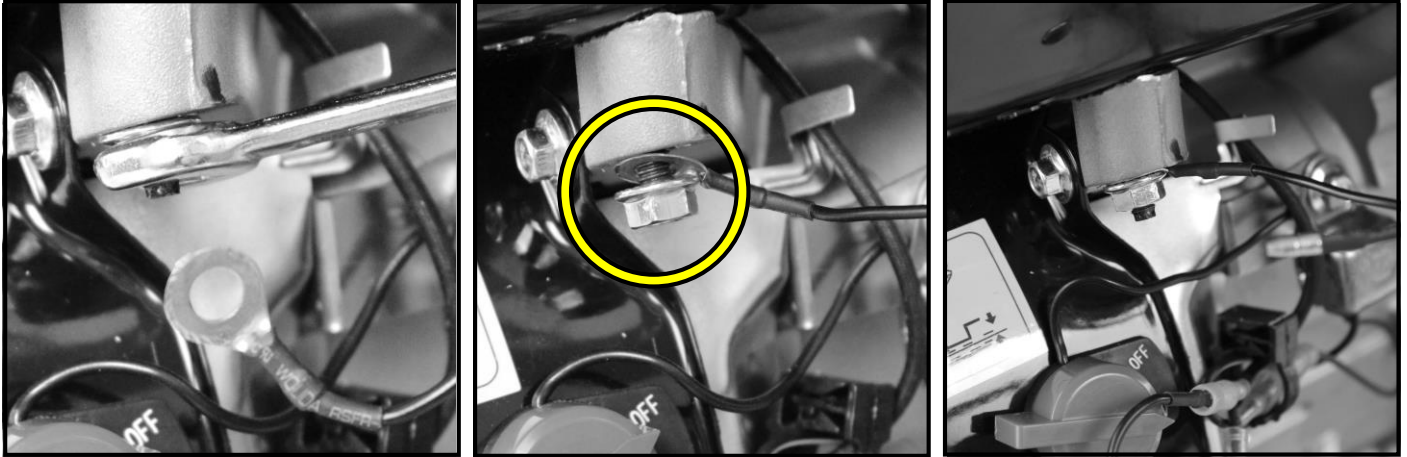

- 3.17 Connect the bullet connector of the emergency stop button to the spare port on the ignition wires located by the engine ignition switch.
- 3.18 Push the bullet connector firmly in to place.



## 4. FUEL & OIL



### CAUTION

This machine is shipped **WITHOUT** Oil and Fuel and will require filling **BEFORE** use. Failure to do so will result in engine damage that will not be covered by the warranty.

Recommended Oil: SAE 30 or 15W40 Engine Oil

Oil Capacity: 600ml

Recommended Fuel: Straight Unleaded Petrol

Fuel Tank Capacity: 3.6Litres



### CAUTION

#### FOR OUTDOOR USE ONLY.

This machine produces carbon monoxide – a poisonous, colourless and odourless gas that can cause death or serious injury.

Petrol is highly flammable, always handle with extreme care and in a well-ventilated area.

**ALWAYS** remove the spark plug HT lead from the spark plug when fuelling or de-fuelling the machine, checking or changing parts.

- 4.0 Unscrew the fuel filler cap and carefully add fresh unleaded petrol.  
**DO NOT** overfill.
- 4.1 Allow a 25mm gap at the top of the fuel tank.
- 4.2 Fuel tank capacity is 3.6l.
- 4.3 Once full, replace and secure the fuel filler cap.

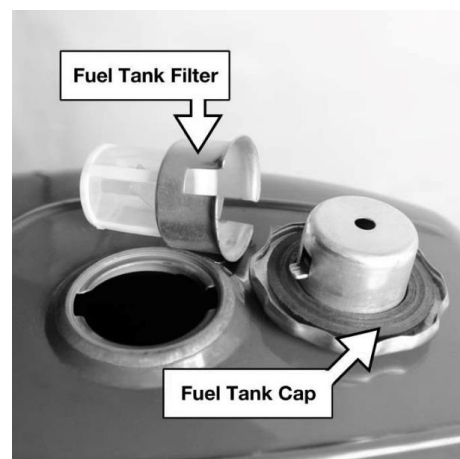

- 4.4 Place the machine on a flat level surface and remove the oil filler cap/dipstick and slowly fill with oil.
- 4.5 Use approx. 600ml of SAE30 or 15W40 engine oil.

- 4.6 Stop occasionally to check the oil level.  
**DO NOT** overfill.
- 4.7 Refit the oil filler/dipstick and tighten securely.

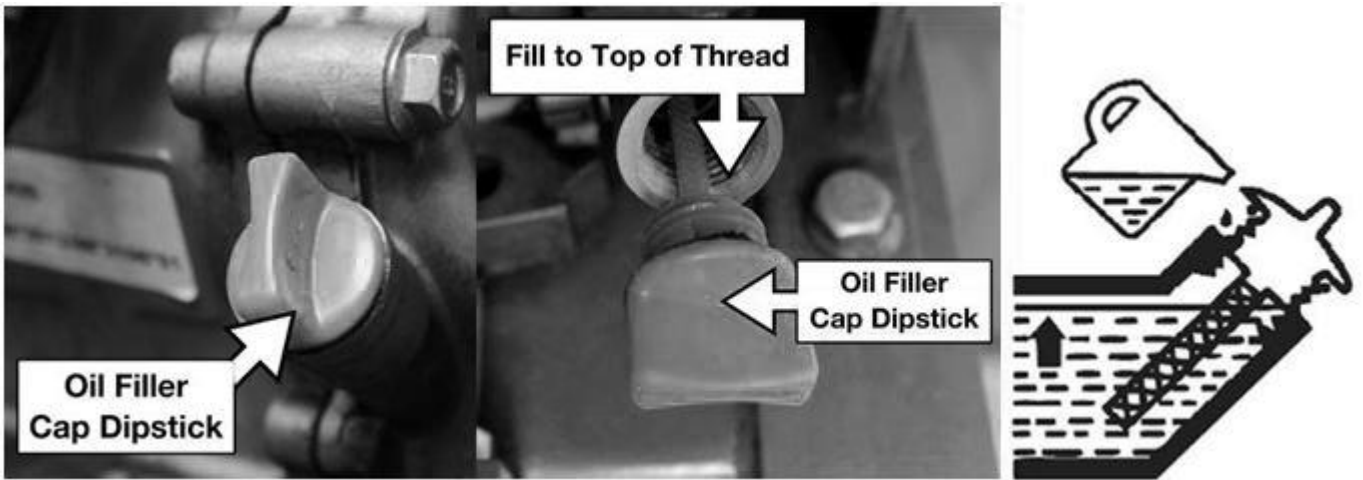

## 5. STARTING PROCEDURE



### CAUTION

This machine is shipped **WITHOUT** Oil and Fuel and will require filling **BEFORE** use. Failure to do so will result in engine damage that will not be covered by the warranty.

Recommended Oil: SAE30 or 15W40 Engine Oil  
Oil Capacity: 600ml

Recommended Fuel: Straight Unleaded Petrol  
Fuel Tank Capacity: 3.6Litres



### NOTE

Before starting, ensure the machine is clear of materials and all non-essential persons.

- 5.0 Check the Emergency Stop button is not in the stop (down) position.
- 5.1 Turn the ignition switch to the ON position.

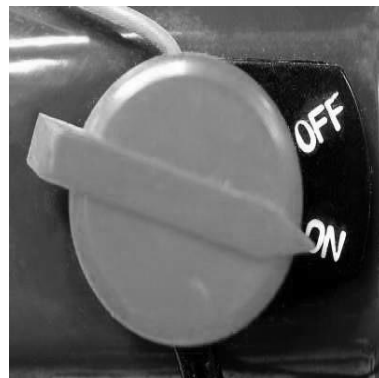

- 5.2 **FOR COLD START:** Move the choke lever left, to the **START** position.
- 5.3 Move the fuel tap to the **ON** position.
- 5.4 Move the throttle lever left to the **MIDDLE** position.
- 5.5 **FOR WARM START:** Use half choke if warm and no choke if hot.

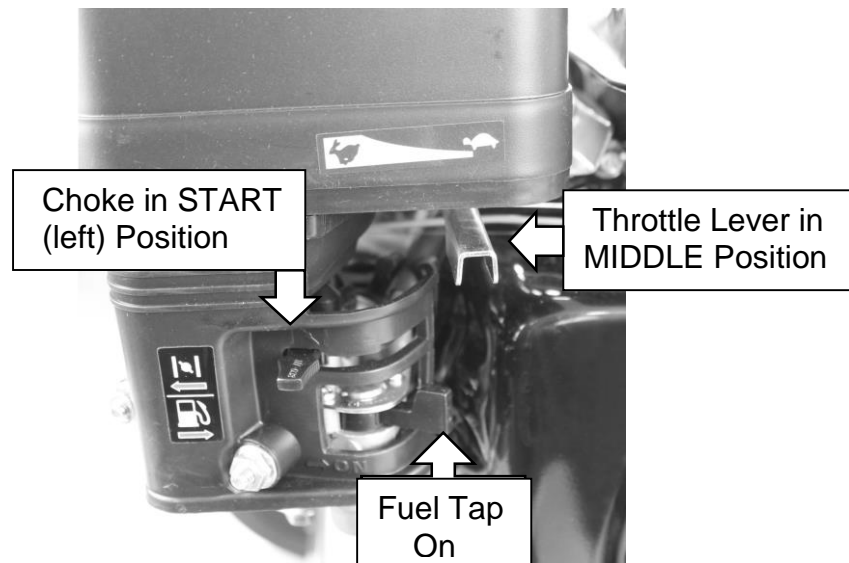

- 5.6 Place one hand on the machine and using your other hand, pull the recoil start handle until you begin to feel resistance.
- 5.7 Once you feel resistance, pull the handle swiftly.
- 5.8 Repeat until the engine starts.  
**DO NOT** let go of the recoil handle, instead return the handle slowly.

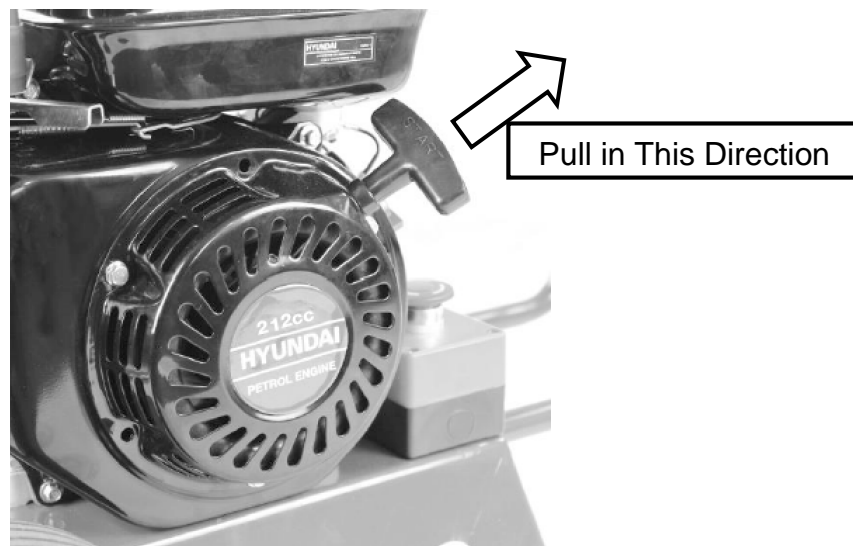

- 5.9 Once the engine has started, reduce the choke by slowly moving the lever right to the **RUN** position.
- 5.10 If the engine falters, move the choke between the START/RUN and adjust until the engine runs smoothly.

5.11

Once the engine has warmed up, move the throttle lever to the left to accelerate the engine to the desired working speed.

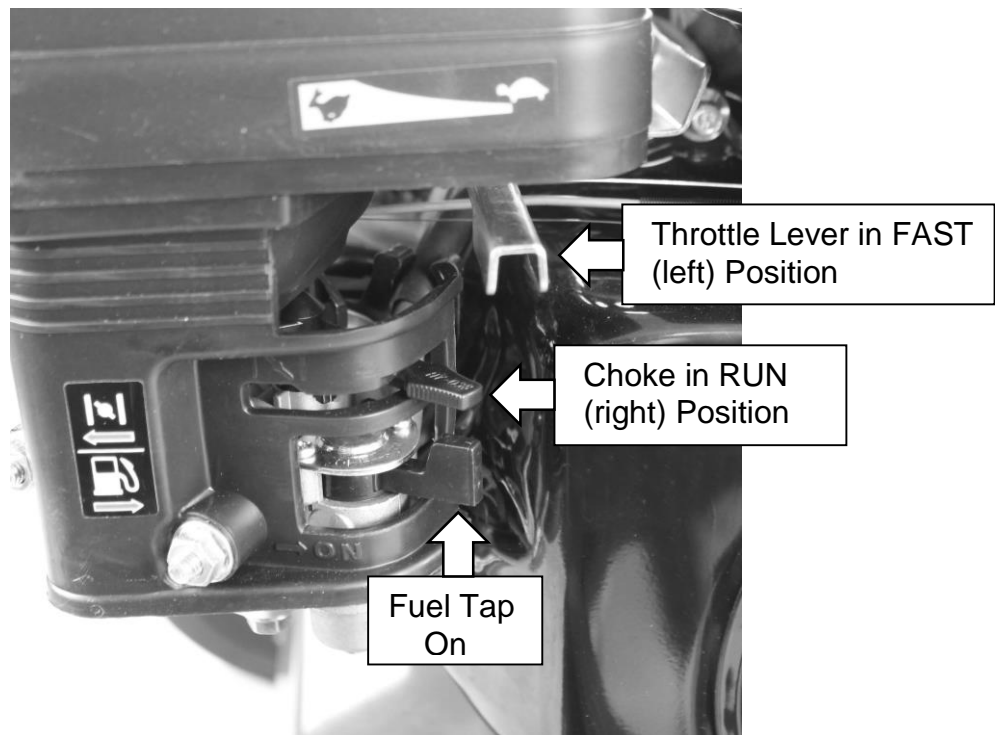

## 6. STOPPING PROCEDURE



### CAUTION

You **MUST** allow the cutting head to come to a complete stop and switch the engine **OFF** before carrying out any maintenance on the machine.

- 6.0 Before stopping the machine, allow the engine to cool down by moving the throttle lever to the **SLOW** position and allowing the engine to idle under no load for 30 seconds.
- 6.1 Turn the power switch to the **OFF** position.
- 6.2 Turn the fuel tap left, to the **OFF** position.

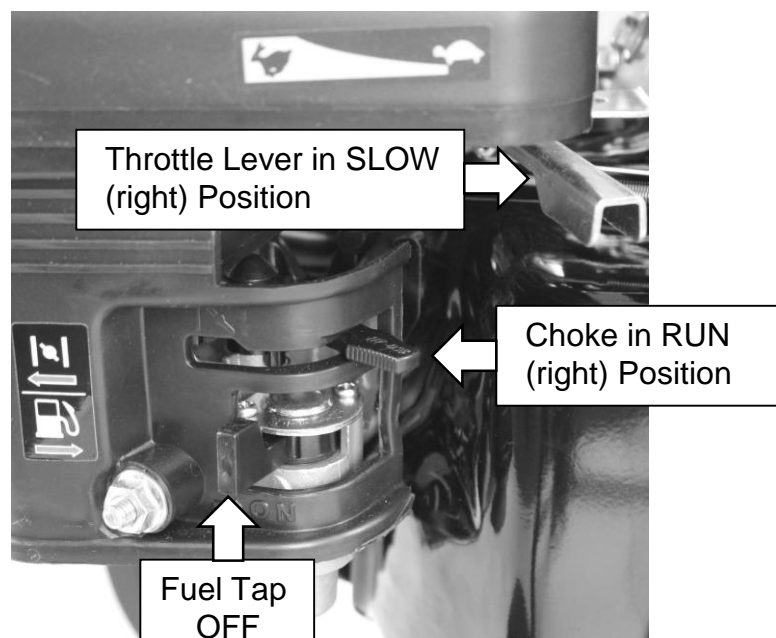

## EMERGENCY STOP

- 6.3 To **STOP** the machine in an emergency, press the emergency stop switch **DOWN**.

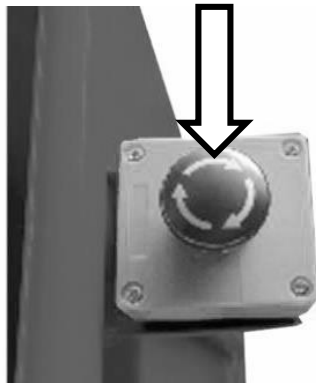

## 7. OPERATING INSTRUCTIONS



### WARNING

You **MUST STOP** using the machine if any of the following occur.  
The engine speed changes with no control.  
In case of misfire or unusual noise.  
In case of high vibration.  
If the belts are slipping.  
In rain or stormy weather.



### CAUTION

If you are not familiar with this type of machine you should seek advice and guidance from your dealer.  
**DO NOT** attempt to lift or move the machine with the engine running.



### CAUTION

#### FOR OUTDOOR USE ONLY

This machine produces carbon monoxide – a poisonous, colourless gas that can cause death or serious injury.  
Petrol is highly flammable, always handle with extreme care and in a well-ventilated area.  
**ALWAYS** remove the spark plug HT lead from the spark plug when checking the machine, refueling or changing parts.

- 7.0 Position the machine on flat, level ground and in such a way so it cannot move during operation.
- 7.1 **DO NOT** overload the machine.  
Use the correct machine for your application.  
The correct machine will do the job better and safer at a rate for which it was designed.

- 7.2 **DO NOT** change the engine governor settings or increase the maximum engine speed.  
The governor controls the maximum safe operating speed of the engine.
- 7.3 **DO NOT** run the engine at a high speed when you are not using it.
- 7.4 **DO NOT** put hands or feet near rotating parts.
- 7.5 The machine has rotating cutting knives capable of amputating hands and feet and throwing objects.  
**AT ALL TIMES** you **MUST** keep hands and feet clear of all openings while the machine is running.  
Failure to observe these safety instructions could result in serious injury or death.
- 7.6 Avoid contact with fuel, oil, exhaust fumes and hot surfaces.
- 7.7 **DO NOT** touch or allow clothing or other flammable materials to come in to contact with the engine or exhaust.  
These parts get extremely hot and will remain hot for a time after operation.
- 7.8 Allow the engine to cool before making any adjustments or maintenance.
- 7.9 If the machine should start to make unusual noises or vibrations, immediately shut off the engine, disconnect the spark plug HT lead and check for the cause.  
Usually noise or vibration is generally a warning of trouble.  
You **MUST** find the source of the problem and fix it before reusing the machine.
- 7.10 Use only attachments and accessories approved by the manufacturer.  
Failure to do so can result in personal injury and may invalidate any warranty.
- 7.11 Maintain the machine and check for misalignment or binding of moving parts, broken parts and any other condition that may affect the machines operation.  
If damaged, have the machine repaired before reuse.
- 7.12 Keep the engine, exhaust and muffler free from grass, leaves, wood chippings, excessive grease or carbon build up to reduce the risk of fire.
- 7.13 **NEVER** pour or squirt the machine with water or any other liquid.  
Keep handles dry, clean and free from debris.
- 7.14 **DO NOT** allow persons unfamiliar with the machine or these instructions to operate it. This machine can be extremely dangerous in the hands of untrained users.
- 7.15 Thoroughly inspect the area to be worked, keep the working area clean and free of debris to prevent tripping. Operate on flat level ground.
- 7.16 **NEVER** place any part of your body where it could be in danger if movement should occur during assembly, installation, operation, maintenance, repair or moving.
- 7.17 Keep all bystanders, children and pets at least 25m away.  
If you are approached, stop the machine immediately.
- 7.18 The operator or user is responsible for preventing accidents or hazards occurring to other people, their property and themselves.
- 7.19 Start the engine carefully according to the instructions.
- 7.20 Before starting the wood chipper, make sure the feed hopper and cutting housing are empty and free of all debris.

- 7.21 **NEVER** place your hands, feet or any part of your body in the chipper hopper, discharge opening, or near or under any moving part while the machine is running. Keep area of discharge clear of people, animals, buildings, glass or anything else that will obstruct clear discharge, causing possible injury or damage. Wind can also change discharge direction, so be aware.
- 7.22 **NEVER** allow the an accumulation of processed material to build up in the discharge hopper area as this will prevent proper discharge and can result in kickback from the chipper hopper.
- 7.23 Keep your face and body back from the chipper hopper and discharge chute to avoid accidental bounce back of any material.
- 7.24 **NEVER** reach with your hands, into the feed hopper past the rubber flap while the machine is operating.
- 7.25 **NEVER** attempt to unclog the feed hopper discharge chute while the engine is running.  
Immediately shut off the engine, allow the cutting disc to come to a complete stop.  
Remove the spark plug HT lead cap.  
Remove the clogged material.  
Inspect for damage and check for any loose parts for repair or replacement.
- 7.26 **DO NOT** tilt the machine while the engine is running.
- 7.27 **ALWAYS** stop the engine before moving the machine.
- 7.28 **ALWAYS** make sure that the engine is switched off and that the cutting disc and engine are at a complete standstill and the spark plug HT lead cap has been removed, before opening the cutting disc housing.
- 7.29 You **MUST** keep all combustible materials and substances away from the engine when it is hot.
- 7.30 **NEVER** cover the machine while the exhaust is still hot.
- 7.31 Feed only clean materials into the machine. Foreign matter like soil, sand, gravel, grit stones, metal etc. will damage the sharp edge of the cutting knives.  
Root balls and dead wood will also dull the blades quickly.
- 7.32 Avoid feeding any flax or roots into the machine, the stringy materials can wrap themselves around the rotor shaft and work their way into the bearings.
- 7.33 **DO NOT** force branches into the machine.  
Allow the machine to automatically feed through.
- 7.34 **NEVER** operate the machine on slopes. Only use on level ground- risk of tipping over if used on a slope.
- 7.35 **DO NOT** alter or adjust any part of the wood chipper or its engine that is sealed by the manufacturer.  
Only a qualified service technician may adjust parts that may increase or decrease governed engine speed.
- 7.36 This wood chipper is for off road use only.  
**NEVER** attempt to tow the machine on public highways, roads or thoroughfares.
- 7.37 **NEVER** operate this machine without the feed hopper or discharge chute properly attached to the machine.

- 7.38 Move the machine at least 3m away from the refueling point before starting the engine.
- 7.39 **ALWAYS** check the oil level of the engine before use.
- 7.40 Inspect the machine and check that all nuts and bolts are tight and well connected to ensure the safety and reliability of this machine prior to use.
- 7.41 Inspect the air pressure in the tyres prior to use and pay attention to sharp objects when moving the machine to prevent the tyres from being pierced.

### Using the Machine

- 7.42 The wood chipper can process a wide variety of dry or green organic materials such as branches, pruning, stalks, vines, leaves and vegetable matter.
- 7.43 The maximum branch diameter is: 60mm
- 7.44 Maximum diameters depend upon the type and hardness of the wood.
- 7.45 Rotate the wood as you feed it into the machine as this will improve performance.
- 7.46 Feed limbs and branches butt end first, leaving the bushy head on.  
This helps the limb to go down the feed hopper and reduces the spinning and bouncing of small pieces back up the feed hopper.  
Some branches may require pre-cutting so that the branch will 'self-feed' more efficiently.
- 7.47 It is advisable to process freshly cut materials as wooden branched gets very hard and springy when dried out and become more awkward to handle by making the knives blunt more quickly.
- 7.48 When operating the machine, keep a wooden stick handy approximately 30mm diameter and 600mm long.  
The stick will be useful to push in short, brushy and very leafy materials and keep the feed hopper clear.
- 7.49 **DO NOT** force material into the machine.  
If it does not chip well, the chipper knives may need sharpening or replacing or the gap between the knives and wear plate needs adjusting.
- 7.50 **DO NOT** overload the machine by feeding too much material into the hopper at one time.
- 7.51 If you hear the engine speed decreasing, immediately stop feeding material into the machine.  
**DO NOT** resume feeding material into the machine until the engine has returned to normal speed.
- 7.52 The wood chipper can clog up with soft, wet or fibrous materials.  
However, if you feed soft materials intermittently with branches, there should be no problem as the wood chipper tends to clear out any residue left in the machine.
- 7.53 If any stringy material becomes wrapped around the rotor shaft.  
Turn off the engine power switch and wait until the cutting disc has come to a complete stop.  
Remove the spark plug HT lead cap.  
You can then remove it before it works its way into the bearing.  
Take care of the sharp blades.

- 7.54 Should the wood chipper stall through overloading or clogging, turn the ignition switch to the off position and wait until the cutting disc has completely stopped. Remove the spark plug HT lead cap. Open the housing cover to clear and remove all the materials from the housing. Lock the housing cover, reinstall the spark plug HT lead cap and start the machine again.
- 7.55 To remove blockages, **DO NOT** under any circumstances use your hands. **STOP** and disable the machine then undo the chutes. Remove the feed and discharge chutes by undoing the securing bolts. Carefully rotate the blades in both directions until the machine is free of materials which have become stuck.
- 7.56 As the discharge materials pile up, move the chipper or the material to keep the outlet free. **DO NOT** position the deflector horizontally as it will reduce the airflow, impeding discharge and cause a blockage.
- 7.57 To reduce stress on the engine when wood chipping is not being performed, set the throttle control lever to its **SLOW** position. Lowering the engine speed to idle will help extend the life of the engine, as well as conserve fuel and reduce the noise level of the machine.
- 7.58 **DO NOT** feed wood into the exit shoot.

## 8. MAINTENANCE



### WARNING

**ALWAYS** stop the engine and disconnect the spark plug HT lead cap **BEFORE** doing any repairs or maintenance.

**NEVER** touch a rotating blade.

Check and maintain the oil and fuel level daily.

Frequently check the wood chipper and make sure that all deposits are removed from the feed hopper and discharge chute.

At regular intervals, check the tightness of all nuts, bolts and screws.

If the blade hits an obstacle, check for damage and if the machine vibrates badly, **STOP** the machine and take it to a service dealer.



### CAUTION

**ALWAYS** refuel and defuel in a well-ventilated area with the engine off and cool.

Whilst carrying out any maintenance, you must wear the appropriate Personal Protective Equipment (PPE).



### CAUTION

**NEVER** use a pressure washer or hose to clean the wood chipper.

Water can penetrate areas of the unit and cause damage to spindles, pulleys, bearings or the engine.

The use of pressure washers or hose pipes will result in a shortened life and reduce serviceability.

Shut down the engine, wait for all moving parts to come to a complete stop, remove the spark plug HT lead cap and wait for the engine to cool **BEFORE** performing any maintenance.

		Each use	1st Month or 20 hours	Every 50 hours	Every 6 months or 100 hours	Every year or 300 hours
Engine oil	Oil Check	*				
	Replace		*		*	
Air Filter	Check	*				
	Clean			*	*	
Air filter Carburetor Float bowl Spark plug	Replace					*
	Clean				*	
	Clean / Adjust				*	
Carburetor Float bowl	Replace					*
Spark arrester	Clean				*	
Idle speed	Check / adjust					*#
Valve clearance	Check / adjust					*#
Fuel filter	Clean					*
Fuel tank	Clean					*
Fuel lines	Check	Check every 2 years – replace as required.				
Cylinder head	Clean	Every 500 hours #				
#- Unless you are mechanically proficient and have the correct tools we recommend that these service items are carried out by an authorised service dealer.						

## AIR FILTER

- 8.0 **NEVER** let the engine run without an air filter being installed.
- 8.1 A dirty air filter element decreases engine performance, increases fuel consumption and makes it difficult to start.
- 8.2 You **MUST** make sure that the housing is free of dust and debris.  
**DO NOT** allow any dust or debris to enter the carburetor.
- 8.3 Remove the air filter housing by unscrewing the nut in an anticlockwise direction.
- 8.4 Carefully remove the cover and remove the air filter element.
- 8.5 Replace the air filter if there are any signs of damage or wear.
- 8.6 Otherwise, remove the air filter and tap the debris from the element.  
Use a low pressure airline to blow the remaining dust from the air filter by blowing from the inside to the out.
- 8.7 Wash the foam filter element in a mild detergent solution and allow to dry.  
Once dry, soak the foam element in engine oil and remove the excess.
- 8.8 Reinstall the air filter.

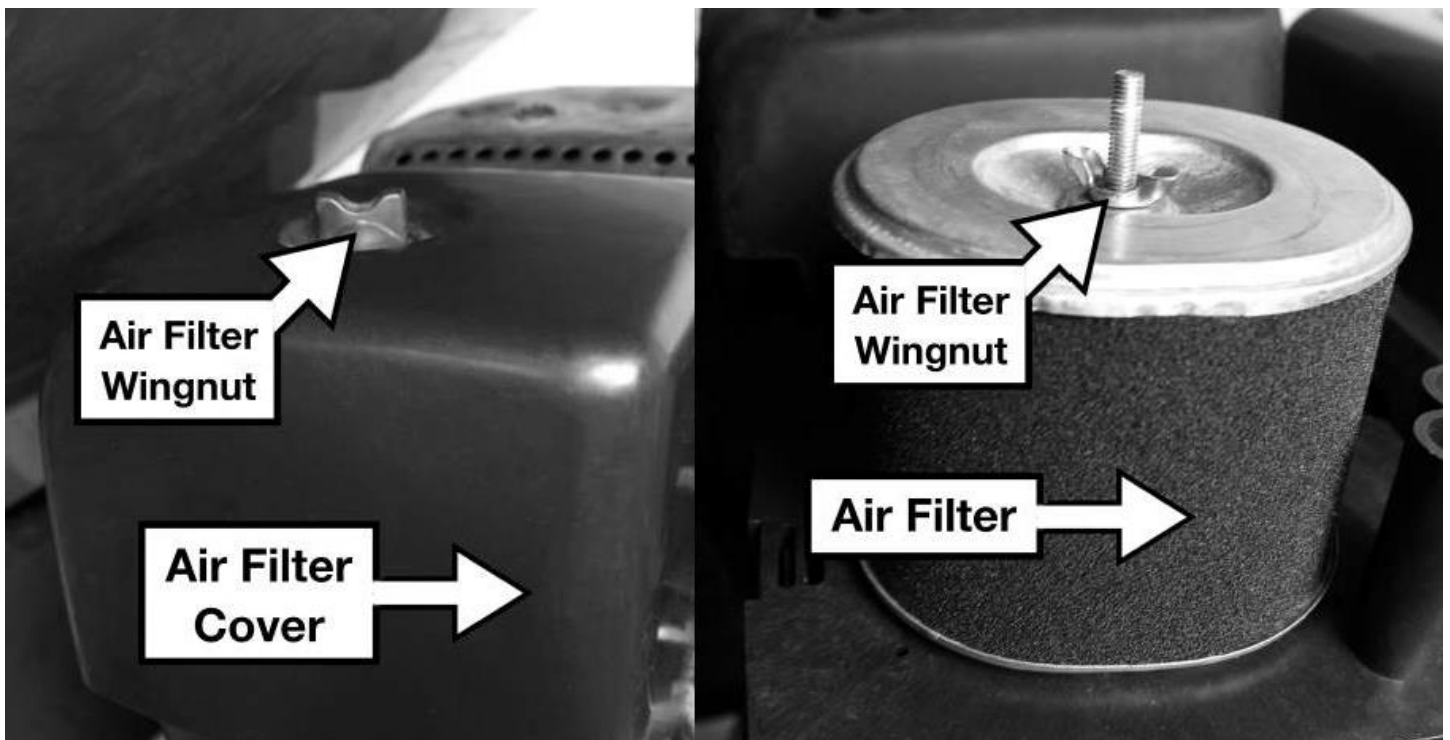

# ENGINE OIL



## CAUTION

Risk of burn injury from **HOT** engine oil.  
Allow the oil to cool to **WARM** before changing the oil.  
Warm engine oil will drain more effectively.

Engine Oil: SAE 30 or 15W40 Engine Oil.  
Oil Capacity: 600ml

- 8.9 Drain the engine oil while the engine is warm. Warm oil drains more effectively.
- 8.10 Remove the oil filler/dipstick and place a suitable container under the drain plug.
- 8.11 Unscrew the drain plug and allow the oil to drain, tilt the machine slightly to ensure all the oil has drained, you may require assistance.
- 8.12 Once all the oil has drained, check the drain plug washer and replace is damaged.
- 8.13 Reinstall the drain plug by hand to avoid cross threading and then tighten with a spanner.
- 8.14 With the machine on flat, level ground, fill the engine with oil to the upper edge of the oil filler/dipstick.
- 8.15 Fill slowly, stopping occasionally to check the oil level.  
**DO NOT OVERFILL.**
- 8.16 Screw the oil filler/dipstick in securely.
- 8.17 Wipe up any spilt oil.

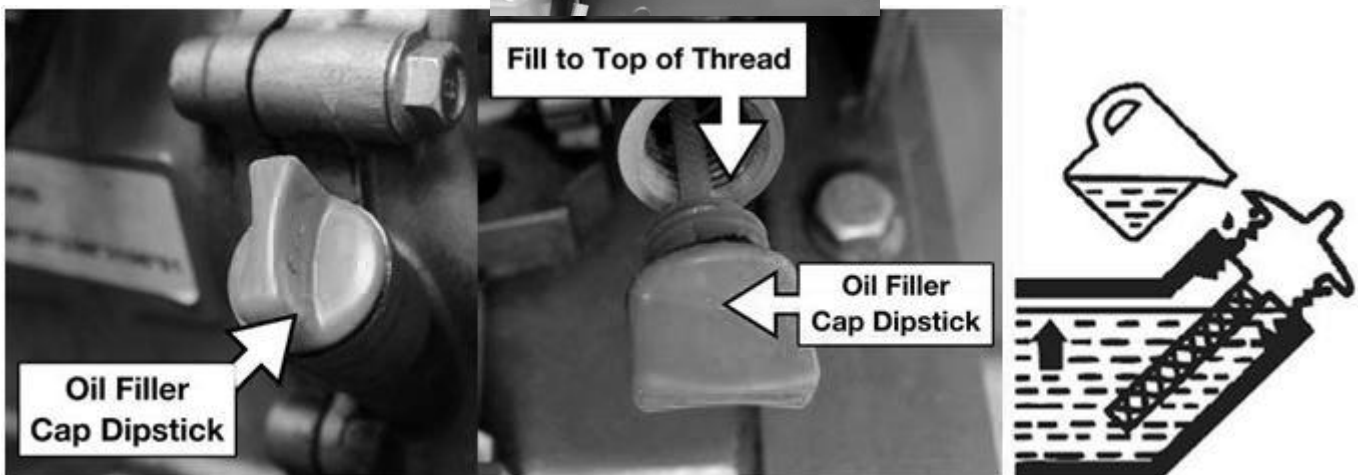
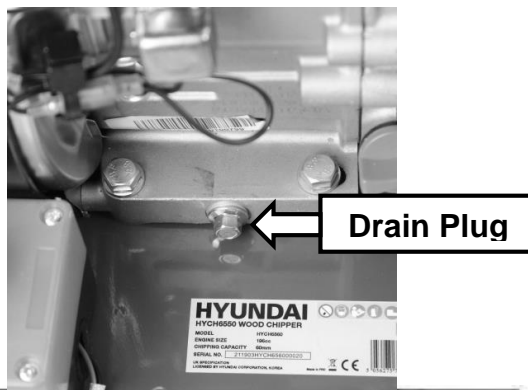

# SPARK PLUG



## CAUTION

The spark plug **MUST** be tightened correctly otherwise the engine will overheat causing damage.

- 8.18 To ensure the engine runs correctly, the spark plug gap of 0.6 – 0.7mm must be maintained and the spark plug must be free of carbon deposits.
- 8.19 To remove the spark plug, remove the spark plug HT lead cap and undo the spark plug in an anticlockwise direction.
- 8.20 Once the plug has been removed, check for visual damage, electrode wear and carbon deposits.  
Replace a damaged or badly worn spark plug.  
Clean off any carbon deposits with a soft wire brush.
- 8.21 Check the spark plug gap with a feeler gauge and adjust the electrode to the correct gap of 0.6 – 0.7mm.
- 8.22 Check the spark plug washer for signs of damage and replace if required.
- 8.23 Replace the spark plug by hand to make sure it doesn't cross thread, tighten the plug to a torque of 12/15Nm.

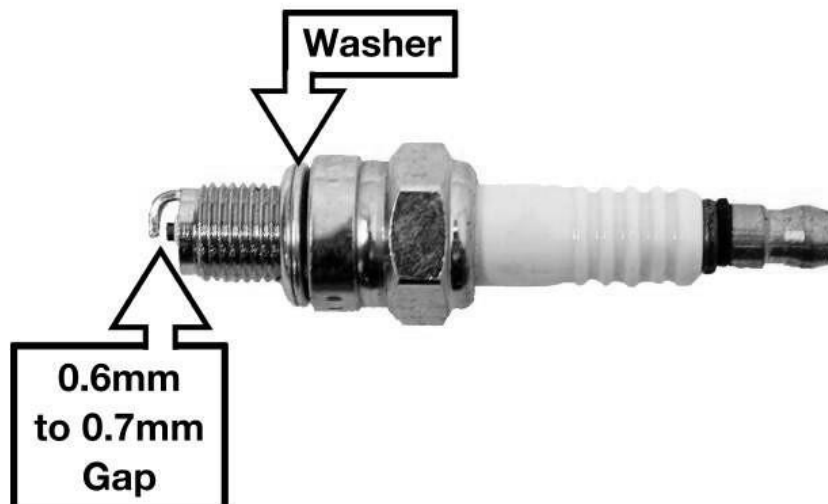
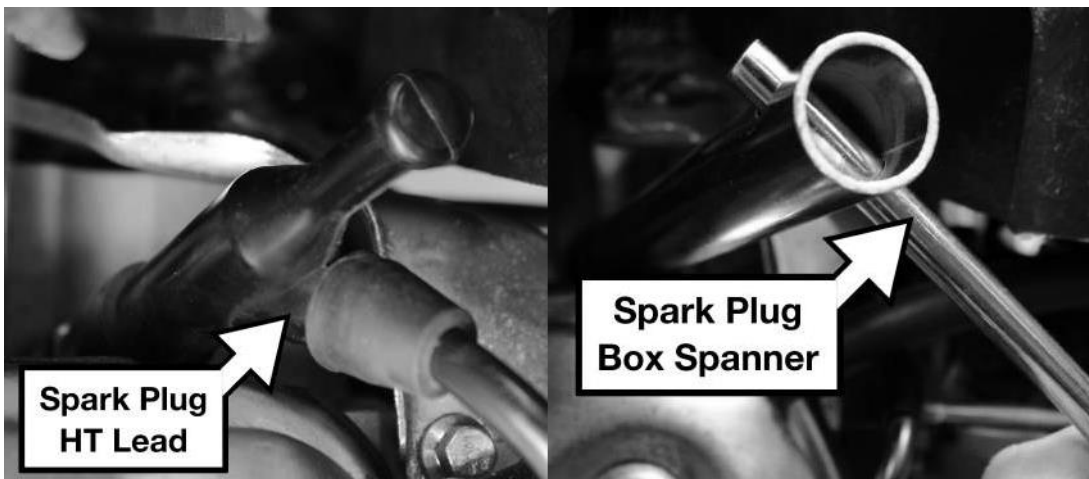

## 9. STORAGE



### NOTE

Improper storage of this machine may cause starting difficulties and may cause permanent damage and will not be covered by the warranty.

- 9.0 Perform the general maintenance from the maintenance section of this manual.
- 9.1 Clean the exterior of the machine.  
**DO NOT** use a pressure washer or hose pipe as this could penetrate the engine with water and cause irreparable damage.
- 9.2 Remove all the fuel from the petrol tank by using either a syphon or by gently tilting the machine (ask for assistance) to drain the fuel in to a suitable container.
- 9.3 Turn **OFF** the fuel tap.
- 9.4 After all the fuel has been removed from the engine, start the engine and allow it to run at idle until the engine stops of its own accord.  
This allows all the fuel in the fuel lines and carburetor to have been drained.
- 9.5 Allow the engine to cool completely.
- 9.6 Remove the spark plug and pour 1 teaspoon of fresh engine oil into the combustion chamber.
- 9.7 Place a clean, lint free cloth over the spark plug hole and gently pull the recoil starter handle 4 to 5 times.  
This coats the internal components with a fresh layer of oil.
- 9.8 Remove the cloth and replace the spark plug by hand to make sure it doesn't cross thread.  
Then tighten the spark plug to a torque of 12/15Nm.
- 9.9 Store the machine in a cool dry place away from any sources of ignition.
- 9.10 Do not stack other items on top of the machine.

## 10. TRANSPORT

- 10.0 **ALWAYS** transport the machine with the fuel tank empty and drain the oil.
- 10.1 Ensure the machine is secured safely and not obstructing vision.
- 10.2 **ALWAYS** ask for assistance when lifting the machine in and out of vehicles.
- 10.3 **NEVER** transport the machine with the engine running.

## 11. TROUBLESHOOTING



### CAUTION

If troubleshooting does not solve the problem, contact the dealer or the manufacturer directly.

Use **ONLY** original parts approved by the manufacturer, otherwise a hazard risk arises.

Common faults		Elimination method
1	The engine will not start	Read the engine users' manual, check the fuel level, ensure the fuel is fresh, ON-OFF switch is ON, lubrication oil level and the emergency stop button.
2	Engine cuts out during operation	Check if the engine stopped due to overloading, check if the discharge chute is clear and that the rotary blade is not jammed, check the emergency stop lever and safety protection switch
3	The hopper is blocked	Stop the machine, and remove the hoppers and clear the blocked material. Don't touch the blade during this procedure.
4	Unusual noises	Stop the machine, check all nuts and bolts are tight, check bearings for excessive play and that blades and belts are not rubbing anywhere.
5	Damaged blades	Fit new blades
6	Belts slipping	Ensure the belt tensioner is adjusted correctly or fit new belts.
7	Poor chipping performance	Adjust the blade clearance, the recommended clearance for rough chipping is 1.5mm-3mm and for fine chipping is 0.5mm-1.2mm.

Issue	Possible Causes	Possible Corrective Actions
STARTING DIFFICULTY NORMAL SPARK ISSUE WITH FUEL SYSTEM	Poor fuel supply. 1. No fuel in fuel system, fuel tap closed. 2. Fuel cap air vent blocked. 3. Fuel tap blocked.  Fuel supply normal. 4. Dirty or stale fuel. 5. Water in fuel. 6. Incorrect fuel.	Poor fuel supply. 1. Fill with fuel - open fuel tap. 2. Clear blocked air vent. 3. Clear blockage.  Fuel supply normal. 4, 5 & 6. Clear fuel from system and refill with fresh fuel.
STARTING DIFFICULTY NORMAL FUEL ISSUE HT LEAD/SPARK PLUG	Normal spark from HT lead. 1. Carbon build up on spark plug. 2. Electrodes badly burnt/damaged. 3. Incorrect spark plug gap.  No spark at HT lead. 4. HT lead damaged. 5. Ignition coil damaged. 6. Gap between ignition coil and flywheel too big.	Normal spark from HT lead. 1. Clean carbon build up. 2. Replace spark plug. 3. Adjust the spark plug gap.  No spark at HT lead. 4. Replace HT lead. 5. Replace ignition coil. 6. Adjust gap.
STARTING DIFFICULTY (ELECTRIC)	Battery connection. 1. Loose or incorrect battery connections. 2. Battery not charged.	Battery connection. 1. Check polarity and tighten connections. 2. Remove battery from machine and recharge.
MACHINE'S WHEELS TRACK LEFT OR RIGHT WHILE BEING TOWED	1. Low tyre pressures.	1. Inflate tyres.
THE SHREDDER DOES NOT SHRED PROPERLY. THE WOOD IS NOT PULLED INTO THE MACHINE BY ITSELF. THE CHIPS DO NOT HAVE THE SAME SIZE.	1. The blades are worn too much. 2. The diameter of the branches inserted into the machine are larger than 60mm. 3. The gap between the fixed blade and the counter-blade is too large, the correct gap is ½ mm.	1. Change or sharpen the blades and counter-blade. Note that the blades are sharpened on both edges so they can be reversed. 2. Shut the engine off and remove the branch that is too thick. 3. Adjust the gap between the blade and the counter-blade in the slots.
THE ENGINE WILL NOT START OR TURN Because THE ROTOR IS JAMMED.	1. The diameter of branches is too big. There are unacceptable materials such as stones or metal in the input tube. A length of branch remains in the rotor after the engine was last stopped.	Shut off the engine, remove the spark plug cap. NEVER under any circumstances use your hands to remove stuck wood. Use a piece of wood to turn the rotor to remove the material from the rotor and input tube. If necessary, remove the cap of the bearing housing and rotate the rotor axle with a spanner. If necessary, remove the input or output tube to get access to the rotor. Check the sharpness of all blades, have them sharpened or replace as required. Make sure all blade bolts are properly tightened.

## 12. SPECIFICATION

Model	HYCH6560
Maximum Chipping Capacity	60mm
Throat Size	25cm x 25cm
Starting Method	Recoil
Engine Type	4 Stroke OHV Single Cylinder Euro 5
Engine Size	212cc
Maximum Output	7HP
Max Blade Speed	2880rpm
Fuel Tank Capacity	3.6L
Fuel Type	Unleaded Petrol
Oil Capacity	0.6L
Oil Type	SAE30 or 15W40
Net Weight	45Kg
Assembled Dimensions (LxWxH)	1600 x 525 x 1030mm

# 13. DECLARATION OF CONFORMITY

13.0 Genpower Ltd confirms that this Hyundai product conforms to the following CE Directives:  
2006/42/EC Machinery Directive  
2004/108/EC EMC Directive  
2000/14/EC Amended by 2005/88/EC Noise Emissions Directive  
97/68/EC\_2010/26/EC NRMM Emissions Directive

## EC DECLARATION OF CONFORMITY

The undersigned. As authorised by: **Genpower Ltd**

Declares that the following equipment manufactured under licensed by Hyundai Corporation, Korea

Conforms to the Directive:-  
**2000/14/EC (as amended)**

Of the European Parliament and of the council on the approximation of the laws of the Member States relating to the noise emission in the environment by equipment for the use outdoors.

Equipment Category:	<b>Power Equipment</b>
Product Name/Model:	<b>HYCH6560</b>
Type/Serial No:	<b>Wood Chipper</b>
Net installed power:	<b>HYCH6560 7hp</b>
The technical documentation is kept by:	<b>Roland Llewellyn, Genpower Ltd Isaac Way, Pembroke Dock, Pembrokeshire, SA72 4RW.</b>

The conformity assessment procedure followed was in accordance with annex V of the Directive.

Notified Body:	<b>Nationaux de Certification Technique 217 Rue Des Reculettes 73123 Paris France Certificate No. N.1818.N.1706081.MD.001</b>
Measured Sound Power Level:	<b>106.9 dBA</b>
Guaranteed Sound Power Level:	<b>108.0 dBA</b>

A copy of this certificate has been submitted to the European Commission and the EU Member State United Kingdom.

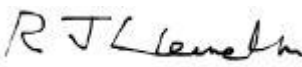





Place of Declaration:	<b>Pembroke Dock, SA73 4RW</b>
Date:	<b>25/02/2019</b>
Signed by:	<b>Roland Llewellyn</b> 
Position in Company:	<b>Managing Director</b>

Name and address of manufacturer or Authorised representative:

**Genpower Ltd  
Isaac Way, Pembroke Dock,  
Pembrokeshire, SA72 4RW**



## 14. RECYCLING & PRODUCT DISPOSAL

- 14.0 We do not offer a take back scheme for the recovery of Waste Electrical Electronic Equipment (WEEE) & Batteries instead the responsibility to dispose of WEEE and or Batteries passed onto you by us. So when it becomes necessary to dispose of your machine you must take it to your local Civic Amenity Site. For further information, please contact your Local Authority for disposal advice.
- 14.1 You MUST make sure that all unused oil and fuel is disposed of correctly either beforehand or at your local Civic Amenity Site. Under NO circumstances must any oil and fuel be put down the drains.
- 14.2 Waste Electrical Electronic Equipment (WEEE) recycling.
- 14.3  Certain products contain WEEE waste which should not be disposed of in your domestic waste.
- 14.4  You MUST recycle WEEE in accordance with your local authority or recycling center.
- 14.5  Battery recycling, certain products contain batteries which should not be disposed of in your domestic waste.
- 14.6  You MUST recycle batteries in accordance with your local authority or recycling center.
- 14.7 Unwanted packaging materials should be sorted and taken to a recycling center so it can be disposed of in a manner which is compatible with the environment.
- 14.8  This symbol means that you should 'Reduce – Reuse – Recycle'.
- 14.9  We are members of the VALPAK National Compliance scheme and our registration number is RM08660.
- 14.10 For further information about disposal please contact your Local Authority.
- 14.11 You can also get more advice and guidance about recycling at the following website <http://www.recycle-more.co.uk>
- 14.12 Should you pass this product on to another user either sold or loaned you MUST pass on this user manual. This will make sure that all other users can use and maintain the machine safely.

## 15. CONTACT DETAILS

- 15.0          POSTAL ADDRESS:          Genpower Limited  
Isaac Way,  
London Road,  
Pembroke Dock,  
Pembrokeshire,  
SA72 4RW. UK.
- 15.1          TELEPHONE:                  01646 687 880
- 15.2          E-MAIL:                          aftersales@hyundaipowerproducts.co.uk
- 15.3          WEBSITE:                        www.hyundaipowerproducts.co.uk

## 16. WARRANTY

- 16.0          Proof of purchase will be required before you make a warranty claim.  
Full warranty terms and conditions can be found on the HYUNDAI POWER  
PRODUCTS website:  
[www.hyundaipowerproducts.co.uk](http://www.hyundaipowerproducts.co.uk)

## 17. MANUAL UPDATES

- 17.0          Our manuals are constantly being reviewed and updated.  
Should you find an error, omission or something you find unclear, please contact  
your dealer for assistance.
- 17.1          All our manuals are placed online.
- 17.2          We reserve the right to make any modifications without prior notice whenever  
necessary.





# HYUNDAI

## POWER PRODUCTS



GENUINE PRODUCT OF  
HYUNDAI CORPORATION

For Inquiries, Please Contact:  
GENPOWER LTD  
Isaac Way, London Road,  
Pembroke Dock, UK, SA72 4RW.  
T: +44 (0) 1646 687 880  
E: [info@hyundaipowerproducts.co.uk](mailto:info@hyundaipowerproducts.co.uk)  
[www.hyundaipowerproducts.co.uk](http://www.hyundaipowerproducts.co.uk)