

HYUNDAI

POWER PRODUCTS

PETROL LAWN MOWER HYM20200SPEX

Instruction Manual



Scan for website
& alternate languages



GENUINE PRODUCT OF
HYUNDAI CORPORATION

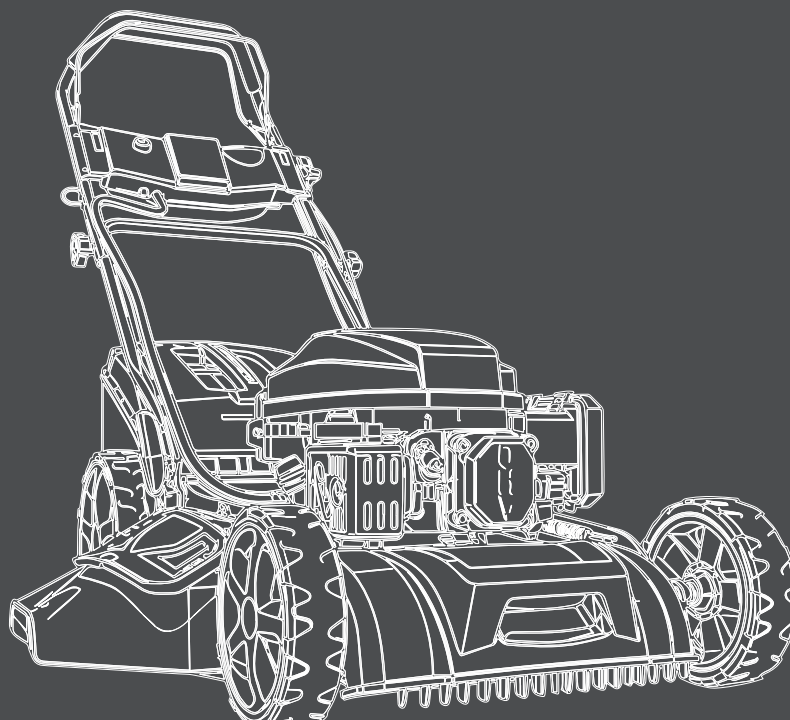

WARNING: Read the instructions carefully before use.

Iss:Apr/26

Contents Page

Contents Page	2	Lawn Care	27
Introduction	3	General Mowing Tips	27
Safety Information	4	How Often Should I mow ?	27
Understand your Machine	4	Replacement & Spares Info	28
Personal Safety	4	General Cleaning	28
Personal Safety (Continued)	5	Maintenance & Care	29
Inspect your Machine	5	General Maintenance	29
Work Area	6	Storage	29
During Use	7	Maintenance Schedule	30
Carbon Monoxide	8	Long Term Storage	30
General Safety	9	Preparation to re-use after storage	30
Spilled Fuel	9	Blade Replacement	31
Fuel Safety	9	Air Filter Maintenance	32
Electrical Safety (Where Applicable)	10	Changing Engine Oil	32
Battery Safety	10	Spark Plug Maintenance	33
Storing Fuel	11	Troubleshooting	34
Fueling/De-Fueling	11	Contact	35
Vibrations (Where Applicable)	12	Recycling & Disposal	36
Noise (Where Applicable)	12	WEEE Information	36
Personal Protective Equipment	13	Environmental Protection	36
Symbols on the Machine	14	Technical Data	37
Intended Use	15	Specification Table	37
Unboxing	16	Declaration of Conformity	38
Features	17	Useful Information	39
Assembly	18	Check Out Our YouTube Channel	39
Handle Assembly	18-19	Warranty	39
Grass Collection Box Assembly	20	Manual Updates	39
Mulching Plug	20	Returning Your Product	39
Side Discharge chute	20	Leaving A Review	39
Pre-Operation Checks	21-22	Ordering Spare Parts	39
Checking Oil Level	21	Product Record	40
Filling with Fuel	22	Notes	41
Operation	23-25	French Language Manual	43-86
Cutting Height Adjustment	23		
Starting with E-Start	24		
Starting with Recoil	25		
Stopping	25		
Solving a "Flooded Engine"	25		
Self Propulsion	26		

Introduction

Thank you for buying your Hyundai Product

We work very hard to give all of our customers the best possible service. If you have any problems, before leaving negative feedback, please contact us to give us a chance to resolve the issue. We would be delighted if you left us positive feedback! Thank you for purchasing this product.

IMPORTANT!



WARNING: READ THE INSTRUCTION BOOKLET THOROUGHLY BEFORE USING THE MACHINE

Keep for future reference and pass it on if the machine is loaned or sold to another user.

This manual has been produced by Hyundai Power Products and should be kept with the product. Please read and understand these instructions before you use your product. Failure to do this may result in personal injury or damage to the product.

The safety precautions and warnings are to ensure your safety and protect you from harm or damage to the product.

The information contained in this manual was accurate at the time of production, however HYUNDAI Power Products may make modifications to the product without notification.

These are the original product instructions. This document is part of the product; retain it for the life of the product, passing it on to subsequent holders. Read this manual in full before attempting to assemble, operate or maintain this product.

This manual describes the purpose of the product and contains all the necessary information to ensure its correct and safe use. Following all the instructions and guidance in this manual will ensure the safety of both the product and the operator and increase the lifespan of the product.

All photographs and drawings within this manual are to help illustrate correct operation of the product. Every effort has been made to ensure the information contained in this manual is accurate. However, we reserve the right to amend this document without prior warning. Always use the latest version of the product manual.

Safety Information

Understand your Machine

- **WARNING!** You must read these instructions carefully before operating the machine. Make sure that you are familiar with the controls and properly operate the machine. You must learn how to stop the machine quickly. If you do not follow the warnings and instructions, it may result in fire and/or serious injury. Make sure to save all warnings and instructions for future reference.
- Read this manual and labels affixed to the machine to understand its limitations and potential hazards.
- Be thoroughly familiar with the controls and their proper operation. Know how to stop the machine and disengage the controls quickly.
- If the unit is to be used by someone other than the original purchaser, or is to be loaned, rented, or sold, always provide this manual and any needed safety training before operation. The user can prevent and is responsible for accidents or injuries that may occur to themselves, to other people, or to property.
- Do not force the machine beyond its limits. Use the correct machine for your application.
- Know how to stop the machine quickly in case of emergency. Understand the use of all controls.
- ALL MAINTENANCE other than that listed in this manual, should be carried out by professionally trained and certified personnel.
- When using this machine for the first time and before actual work, you **MUST** learn how to handle the machine from an experienced or skilled person.

Personal Safety

- **WARNING!** Never allow children or people unfamiliar with these instructions to use the product. Local regulations can restrict the minimum age of the operator.
- Keep children, pets, and other people not using the unit away from the work area (at least 15m). Be alert and shut off the unit if anyone enters work area. Keep children under the watchful care of a responsible adult.
- Stay alert, watch what you are doing and use common sense when operating the machine. Never operate the machine when unwell or tired, or if you have taken alcohol, medicine, drugs or any substances which may slow your reflexes and compromise judgment. A moment of inattention while operating the machine may result in serious personal injury.
- Appropriate Personal Protective Equipment (PPE), **MUST** be worn at all times when operating or repairing the machine. Always wear anti-slip and resistant work footwear and long trousers while using the machine. Do not use the machine when barefoot, wearing sandals or similar lightweight footwear. Do not wear chains, bracelets or clothing that is loose fitting or hanging ties or cords. Tie long hair back. Always wear protective ear-plugs. Loose clothes, jewellery, or long hair can be caught in moving parts. Protect eyes, face, and head from objects that may be thrown from the unit. Always wear safety goggles or safety glasses with side shields when operating.
- Always keep hands and feet away from all moving parts during operation. Moving parts can cut or crush body parts. Always keep hands and feet away from all pinch points.

Safety Information

Personal Safety (Continued)

- Do not touch parts that might be hot from operation. Allow parts to cool before attempting to maintain, adjust, or service.
- Do not overreach. Keep proper footing and balance at all times. This enables better control of the machine in unexpected situations. Extending your body too far can result in a loss of balance and you may fall which will result in injury.
- Never place any part of your body where it would be in danger if movement should occur during assembly, installation, and operation, maintenance, repairing or moving.
- Keep in mind that the operator or user is responsible for accidents, hazards or unexpected events involving the machine that occur to other people or their property. It is the responsibility of the user to assess the potential risk of the area where work is being carried out. The operator or user must take all necessary precautions to ensure their own safety and that of others, especially on slopes or rough, slippery and unstable ground.

Inspect your Machine

- Check your machine before starting it. Keep guards in place and in working order. Make sure all nuts, bolts, etc., are securely tightened.
- You must check the general condition of the machine before use.
- Never operate the machine when it is in need of repair or is in poor mechanical condition. Replace damaged, missing, or failed parts before using it. Keep the machine in safe working condition.
- Do not use the machine if the machine's OPC lever does not turn off the machine when running. Any machine that can't be controlled with the OPC is dangerous and must be replaced.
- Regularly check to see that keys and adjusting wrenches are removed from the machine area before starting it. A wrench or a key that is left attached to a rotating part of the machine may result in personal injury.
- If the machine should start to vibrate abnormally, stop the machine and check immediately for the cause. Vibration is generally a warning sign of trouble.
- Avoid accidental starting. Be sure the OPC is disengaged before transporting the machine or performing any maintenance or service on the unit. Transporting or performing maintenance or service on a machine with the OPC engaged invites accidents.
- Do not tamper with or disable safety systems.
- Only use manufacturer-recommended attachments.
- Before using, always visually inspect to see that the tools are not worn out or damaged. Replace worn out or damaged elements and bolts in set to preserve balance.
- Keep the machine in good operating condition. Operating the machine in poor or questionable condition could result in serious injury.
- Be sure all safety devices are in working order and warning labels are in place. These items are installed for your safety.

Safety Information

Work Area

- Make sure you thoroughly inspect the entire work area and remove all objects and anything that could be thrown by the machine or could damage the engine or machine (branches, stones, wire, toys, etc). Attempting to clear the work area whilst using the machine will reduce your concentration and creates a trip hazard. Any liquid spilled on the floor may result in you slipping.
- You must only work in daylight or with good artificial light in good visibility conditions. Do not work at night, at times of heavy fog, or at any other times when your field of vision might be limited and it would be difficult to gain a clear view of the area.
- Keep people, children and animals away from the working area.
- Operate on level ground.
- DO NOT work on wet ground. If there has been heavy rain on the working area, wait until the ground has dried up.
- You must pay special attention when approaching obstacles that could compromise visibility.
- Exercise extreme caution when changing direction on slopes. When changing direction, you need to be careful that the wheels do not hit any obstacles (such as roots, branches, stones, etc) that can cause the machine to slide sideways or make you lose control of it. Avoid operating on slopes steeper than 15%. Make sure on slopes you have a steady foothold.
- Find and locate all fixed objects in the ground, such as sprinkler systems, poles, water valves, bases for washing lines etc. Make sure that you check for hidden electrical cables or similar on the surface of the lawn. ALWAYS run the machine around these objects. NEVER intentionally run the machine over foreign objects.
- Never park the machine in a place with unstable ground which could give way.
- You must be careful near ravines, ditches or embankments.
- Exercise extreme caution when operating near or crossing gravel drives, walks, or roads. Stay alert for hidden hazards or traffic.
- Pay the utmost attention when working on frozen ground as the machine may tend to skid.
- Do not work in the rain, when there is a thunderstorm or lightning risk, at times of strong or gale force winds, or at any other times when the weather conditions might make it unsafe to use this product. If there is bad weather conditions, do not use the machine.

Safety Information

During Use

- Always hold the unit with both hands when operating. Keep a firm grip on the handlebars. Be aware that the machine may unexpectedly bounce upward or jump forward if the machine should strike buried obstacles such as large rocks or roots.
 - Do not operate the machine in confined areas where there may be a risk of crushing the operator between the machine and another object.
 - Walk, never run with the machine. Be very careful when pulling the machine toward you. You must look behind you to make sure there are no obstacles before and during operations in reverse gear (if applicable). Do not allow the machine to pull you along.
 - **WARNING!** If something breaks or an accident happens whilst working, you must turn off the engine immediately and move the machine away to prevent further damage. If an accident happens with injuries or third parties are injured, carry out the first aid measures most suitable for the situation immediately and contact the medical authorities for any necessary health care. Carefully remove any debris that might cause damage or harm persons or animals should it not be seen.
 - Disengage clutch lever before starting the engine.
 - Use extreme caution when reversing or pulling the machine backwards.
 - Do not carry passengers.
 - Never operate the machine at a fast pace.
 - The excessive speed of movement or the absence of maintenance have a significant influence on noise emissions and vibrations. It is necessary to take preventive steps to eliminate possible damage due to high levels of noise and stress from vibration. You must maintain the machine well, wear ear protection and take breaks from working.
 - After striking a foreign object, stop the engine immediately, remove the spark plug cap and inspect the machine thoroughly for damage. Repair the damage before continuing.
 - Never attempt to make any adjustments, while the engine is running.
 - Never attempt to move the machine in any way other than intended for normal use while the engine is running.
 - Factory-fitted control devices, such as the handle-mounted clutch cable, must not be removed or exposed.
-
- You must disengage the blade, switch off the engine (making sure that all moving parts are stationary):
 - Before refuelling.
 - Before adjusting the cutting height.
 - After striking a foreign object, you must inspect the machine for damage and make repairs before using it again.
 - Before checking or working on the machine.
 - Before clearing blockages.
 - When transporting the machine.
 - Whenever you leave the machine unattended.
 - When crossing surfaces other than grass.
 - Before emptying the grass collector.
 - Before changing the cutting height.

Safety Information

Work Area

- Make sure you thoroughly inspect the entire work area and remove all objects and anything that could be thrown by the machine or could damage the engine or machine (branches, stones, wire, toys, etc). Attempting to clear the work area whilst using the machine will reduce your concentration and creates a trip hazard. Any liquid spilled on the floor may result in you slipping.
- You must only work in daylight or with good artificial light in good visibility conditions. Do not work at night, at times of heavy fog, or at any other times when your field of vision might be limited and it would be difficult to gain a clear view of the area.
- Keep people, children and animals away from the working area.
- Operate on level ground.
- DO NOT work on wet ground. If there has been heavy rain on the working area, wait until the ground has dried up.
- You must pay special attention when approaching obstacles that could compromise visibility.
- Exercise extreme caution when changing direction on slopes. When changing direction, you need to be careful that the wheels do not hit any obstacles (such as roots, branches, stones, etc) that can cause the machine to slide sideways or make you lose control of it. Avoid operating on slopes steeper than 15%. Make sure on slopes you have a steady foothold.
- Find and locate all fixed objects in the ground, such as sprinkler systems, poles, water valves, bases for washing lines etc. Make sure that you check for hidden electrical cables or similar on the surface of the lawn. ALWAYS run the machine around these objects. NEVER intentionally run the machine over foreign objects.
- Never park the machine in a place with unstable ground which could give way.
- You must be careful near ravines, ditches or embankments.
- Exercise extreme caution when operating near or crossing gravel drives, walks, or roads. Stay alert for hidden hazards or traffic.
- Pay the utmost attention when working on frozen ground as the machine may tend to skid.
- Do not work in the rain, when there is a thunderstorm or lightning risk, at times of strong or gale force winds, or at any other times when the weather conditions might make it unsafe to use this product. If there is bad weather conditions, do not use the machine.

Safety Information

During Use

- Always hold the unit with both hands when operating. Keep a firm grip on the handlebars. Be aware that the machine may unexpectedly bounce upward or jump forward if the machine should strike buried obstacles such as large rocks or roots.
 - Do not operate the machine in confined areas where there may be a risk of crushing the operator between the machine and another object.
 - Walk, never run with the machine. Be very careful when pulling the machine toward you. You must look behind you to make sure there are no obstacles before and during operations in reverse gear (if applicable). Do not allow the machine to pull you along.
 - **WARNING!** If something breaks or an accident happens whilst working, you must turn off the engine immediately and move the machine away to prevent further damage. If an accident happens with injuries or third parties are injured, carry out the first aid measures most suitable for the situation immediately and contact the medical authorities for any necessary health care. Carefully remove any debris that might cause damage or harm persons or animals should it not be seen.
 - Disengage clutch lever before starting the engine.
 - Use extreme caution when reversing or pulling the machine backwards.
 - Do not carry passengers.
 - Never operate the machine at a fast pace.
 - The excessive speed of movement or the absence of maintenance have a significant influence on noise emissions and vibrations. It is necessary to take preventive steps to eliminate possible damage due to high levels of noise and stress from vibration. You must maintain the machine well, wear ear protection and take breaks from working.
 - After striking a foreign object, stop the engine immediately, remove the spark plug cap and inspect the machine thoroughly for damage. Repair the damage before continuing.
 - Never attempt to make any adjustments, while the engine is running.
 - Never attempt to move the machine in any way other than intended for normal use while the engine is running.
 - Factory-fitted control devices, such as the handle-mounted clutch cable, must not be removed or exposed.
-
- You must disengage the blade, switch off the engine (making sure that all moving parts are stationary):
 - Before refuelling.
 - Before adjusting the cutting height.
 - After striking a foreign object, you must inspect the machine for damage and make repairs before using it again.
 - Before checking or working on the machine.
 - Before clearing blockages.
 - When transporting the machine.
 - Whenever you leave the machine unattended.
 - When crossing surfaces other than grass.
 - Before emptying the grass collector.
 - Before changing the cutting height.

Safety Information

Battery Safety



There is an explosion risk if the battery terminals are short circuited, when connecting/disconnecting ALWAYS exercise great care so that the terminals or battery leads are NOT allowed to touch and cause a spark. ALWAYS use suitable insulated tools.

Batteries present a risk if they become damaged by the possible leaking of electrolyte. This electrolyte is an acid and can cause serious burn injuries. Care should be taken when working on or near them. NOTE the electrolyte may be in a liquid or gel form. Should you come in to contact with electrolyte you should;

- Remove all clothing contaminated with electrolyte. If you cannot remove then saturate them in water.
- Get medical assistance as soon as possible.

. This machine contains LiFePO4 batteries with lipf6 electrolyte.

- Use fresh running water to wash off excess electrolyte, continue this until medical assistance arrives. Make sure that you do not wash the electrolyte to another part of your body or face.
- If electrolyte comes in to contact with Eyes the electrolyte needs to be immediately washed away with large amounts of water. Make sure that you do not wash the electrolyte to another part of your face or body.
- Gasses from charging batteries are highly flammable and great care should be taken to charge in well ventilated areas.

Electrical Safety (Where Applicable)

Prior to carrying out any maintenance work you MUST identify electrical isolation methods and isolate all electrical supplies.

- Prior to use and with all electrical supplies isolated, you MUST check all electrical cables, plugs and connectors for the following;
 - Are intact and have no signs of damage, to include but not limited to bare wires, chaffing, cuts and loose wiring.
 - If there are any signs of damage, the damaged item MUST be taken out of service until the damage has been repaired by an electrically competent person.
 - All trailing cables should be routed so as not to cause any kind of trip hazard.
 - NEVER work on or near electricity with wet hands, wet clothing and wet gloves.

Safety Information

Fueling/De-Fueling

- ALWAYS fuel and de-fuel in a well ventilated area outside of buildings. Use a funnel to add fuel, only outdoors. Do not smoke during this and each time fuel is handled.
- Add fuel before igniting the engine, never remove the fuel tank cap or add fuel whilst the engine is running or when it is hot.
- When de-fueling ALWAYS use a proper fuel retriever.
- Never overfill the fuel tank. Engine heat can cause fuel to expand, never fill the tank to more than 1/2" below the bottom of the filler neck. This will provide space for fuel expansion.
- When refilling or draining the fuel tank, use an approved fuel storage container while in a clean, well-ventilated outdoor area. While adding fuel or operating the unit, do not smoke, and stay away from sparks, open flames, or other sources of ignition near the area of operation.
- Always stop the engine and allow it to cool before filling the fuel tank. Never remove the cap of the fuel tank or add fuel while the engine is running or when the engine is hot.
- Loosen the fuel tank cap slowly to relieve any pressure in the tank.
- ALWAYS keep the handles dry, clean and free of oil and fuel.
- After fueling, ensure to tighten the cap securely.
- Never use the lock-function when filling with fuel.

Storing Fuel

- Store fuel in containers specifically designed and approved for fuel storage.
- Store fuel in a cool, well-ventilated area, safely away from sparks, open flames, or other sources of ignition.
- Never store fuel – or a machine with fuel in the tank – inside a building where fumes may reach a spark, open flame, or any other source of ignition (such as a water heater, furnace, or clothes dryer). Allow the engine to cool before storing in any enclosure.
- Replace all fuel tank and container caps securely and wipe up spilled fuel. Never operate the unit without the fuel cap securely in place.

Safety Information

Vibrations (Where Applicable)

- The operating noise of the machine can damage your hearing. When wearing protection such as earplugs or ear defenders to protect your hearing. Long-term and regular users are advised to have hearing checked regularly. Be especially vigilant and cautious when wearing ear protection because your ability to hear alarm warnings will be reduced.
- Noise emissions for this equipment is unavoidable. Carry out noisy work at approved times and for certain periods. Limit the working time to a minimum. For your personal protection and protection of people working nearby it is also advisable for them to wear hearing protection.
- See Certificate of Conformity section for Outdoor Noise declaration of conformity.

Noise (Where Applicable)

- The operating noise of the machine can damage your hearing. When wearing protection such as earplugs or ear defenders to protect your hearing. Long-term and regular users are advised to have hearing checked regularly. Be especially vigilant and cautious when wearing ear protection because your ability to hear alarm warnings will be reduced.
- Noise emissions for this equipment is unavoidable. Carry out noisy work at approved times and for certain periods. Limit the working time to a minimum. For your personal protection and protection of people working nearby it is also advisable for them to wear hearing protection.
- See Certificate of Conformity section for Outdoor Noise declaration of conformity.

Safety Information

Personal Protective Equipment

Appropriate Personal Protective Equipment (PPE), MUST be worn at all times when operating or repairing the machine. No protective equipment can ensure 100% protection. When selecting PPE, make sure it's CE marked and it suits the user in terms of size, fit, etc. If more than one item of PPE is worn at the same time, make sure they can be used together, e.g. wearing safety glasses may disturb the seal of a respirator, causing air leaks.



Hand Protection Must Be Worn

Protective electrically non-conductive gloves are highly recommended when working.



Foot Protection Must Be Worn

Non-skid heavy duty footwear are highly recommended when working.



Hearing Protection Must Be Worn

Suitable safety hearing protection is recommended.



Eye Protection Must Be Worn

Always wear safety glasses/goggles and/or face shields. Everyday eye-glasses have only impact resistant lenses; they are not safety glasses/goggles.



Protective Clothing Must Be Worn

Do not wear loose clothing, gloves, scarfs, neckties or jewellery (rings, wrist watches), which can be caught in moving parts.



Head Protection Must Be Worn

Wear a safety helmet with a safety visor.











Face Shield Must Be Worn

Wear a face shield to protect your face

Safety Information

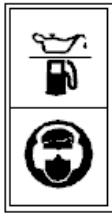
Symbols on the Machine

We have provided safety messages in this manual and on the machine. This information alerts you to potential hazards that could hurt you or others. Please read these messages carefully. However, we may not have listed all of the possible hazards, you must also use your own judgement.

Symbol	Description	Symbol	Description
	WARNING, if you don't understand the risks of this machine you are a risk. Read the manual operate the machine safely		Do not refuel the machine whilst the machine is running
	Projectile warning. This machine has the risk of creating projectiles, keep a safe distance to people with the work area		Hot surface warning. Do not touch surfaces near this sticker as there is a risk of burning
	Carbon monoxide warning. This machine must be operated in a well ventilated area		Fuel and Eyewear. This machine requires petrol and always wear protective eyewear
	Waste electrical products should not be disposed of with household waste. Please recycle where facilities exist. Check your local authority or retailer for recycling advice.		This product complies with the European directives and an evaluation method of conformity for these directives was done
	The UKCA (UK Conformity Assessed) marking is a UK product marking that is required for goods being placed on the market in Great Britain (England, Wales and Scotland).		Sound power level LWA data in dB.

Safety Information

Intended Use

The HYM20200SPEX is a petrol lawnmower from HYUNDAI. The HYM20200SPEX has a cutting width of 506mm and is powered by a 196cc Motor

The HYM20200SPEX is a garden tool and precisely a pedestrian controlled lawnmower. The machine is essentially composed of a motor which drives a blade enclosed in a casing, equipped with wheels and a handle. The operator is able to operate the machine and use the main controls, always staying behind the handle at a safe distance from the rotating blade.

If the operator leaves the machine, the machine will stop.

The lawnmower is manufactured according to the latest safety requirements. These include a blade brake that stops the machine and blade when you let go of the OPC lever. Every precaution is only effective when it is followed exactly.

Intended Use

This machine was designed and manufactured for cutting and collecting grass in gardens and grassy areas, in areas in proportion to its cutting capacity, controlled by a pedestrian operator.

User Types

This machine is intended for use by consumers, i.e. non professional operators. The machine is intended for "DIY" and domestic use only.

This garden tool is not intended for use by persons (including children) with reduced physical, sensory or mental capabilities, or lack of experience and knowledge, unless they have been given supervision or instruction concerning use of the machine by a person responsible for their safety. Never allow children or people unfamiliar with these instructions to use the garden tool.

Supervise children. This will ensure that children do not play with the unit.

Any other use is not as intended. Improper use is not covered by the warranty and the manufacturer will reject any liability. The user is liable for all injuries to third parties and damage to their property. Operate the unit only in the technical condition as stipulated and delivered by the manufacturer. Arbitrary changes to the unit will exclude the manufacturer from any liability for resulting injury and/or damage.

Improper Use

Any other usage not in keeping with the above mentioned ones may be hazardous and harm persons and/or damage things. Examples of improper use may include, but are not limited to:

- transporting people, children or animals on the machine
- letting yourself be transported by the machine
- using the machine to tow or push loads
- using the machine for leaf or debris collection
- using the machine to trim hedges, or cutting anything other than grass
- use of the machine by more than one person
- using the blade on surfaces other than grass

Unboxing

⚠ WARNING : Unboxing and assembling the machine should be done on a flat, surface with enough room. Disposal of the packaging should be done in accordance with the local regulations in force.

⚠ WARNING : Some of the packaging material may be harmful to children. Keep out of reach of children.

1. Carefully remove the product from the packaging and examine it for any sign of damage caused during shipping.
2. Lay the contents out and check them. If any part is damaged or missing, you must not use the machine. Contact HYUNDAI POWER PRODUCTS immediately.
3. You must keep the packaging material in case the machine needs to be returned or repaired.
4. Ensure that you have all the accessories and tools you need for assembly and operation including the suitable personal protective equipment.

We recommend that you fill out the information in the 'Product Record' section. If you need to contact an authorised dealer or customer service, you may need to provide this information.

Features

* NOT TO SCALE

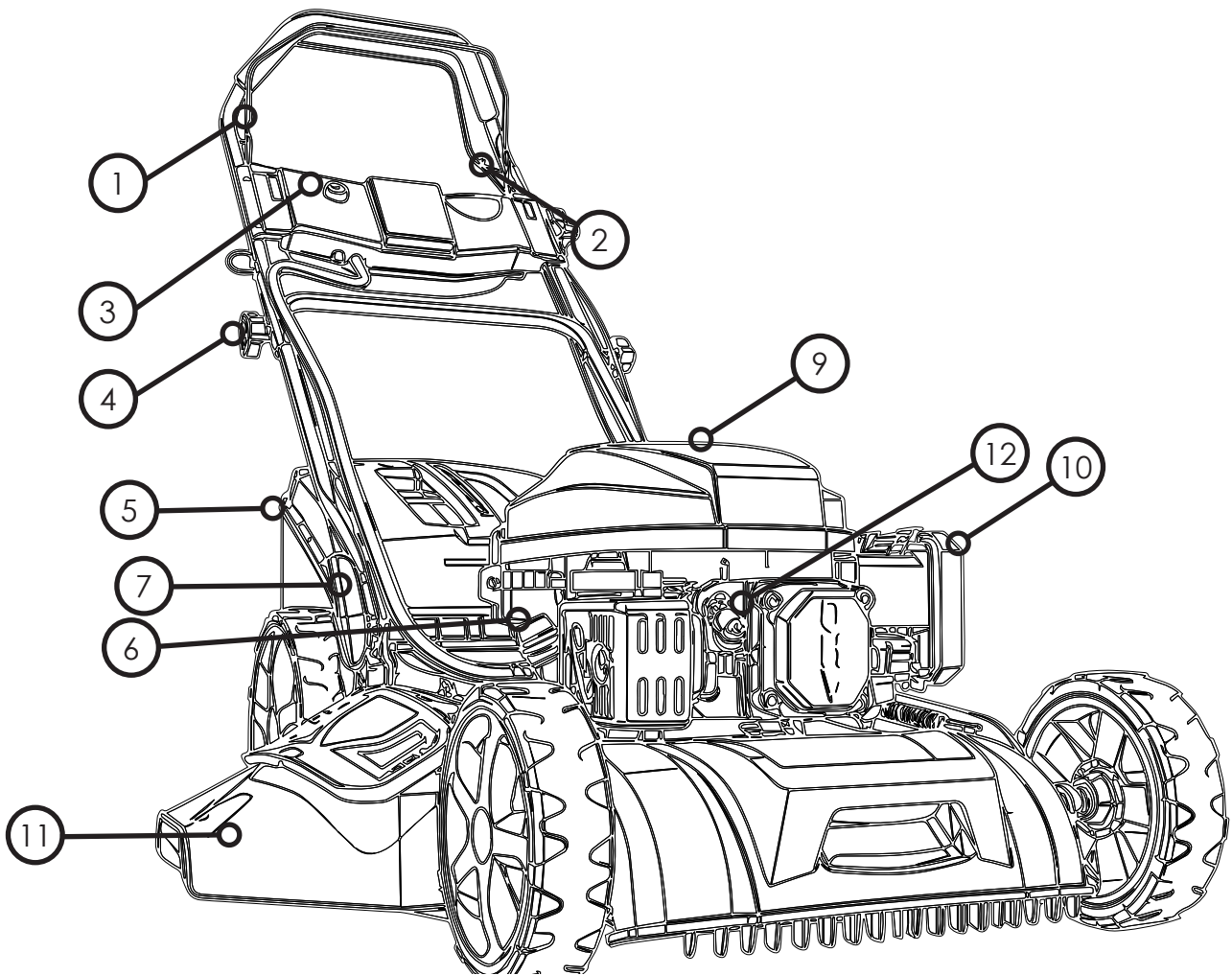

1. Drive lever (clutch lever)
2. OPC Lever
3. Start button
4. Quick lock handle
5. Grass Collection box
6. Engine oil cap
7. Height adjusting handle
8. Recoil Starter handle
9. Fuel tank cap
10. Air filter
11. Side discharge cover
12. Sparkplug connector

Assembly

Handle Assembly

NOTE: When assembling the handles, ensure the recoil holder (pictail) is on the right hand side of the machine, when stood behind it.

Step 1 : Assemble the lower handles.

Place the bolt from the outside of the mower deck bracket, ensuring the lower handle is resting on the Lower Handle Support.

Secure into place with the washer and hand knob nut. Repeat on both sides

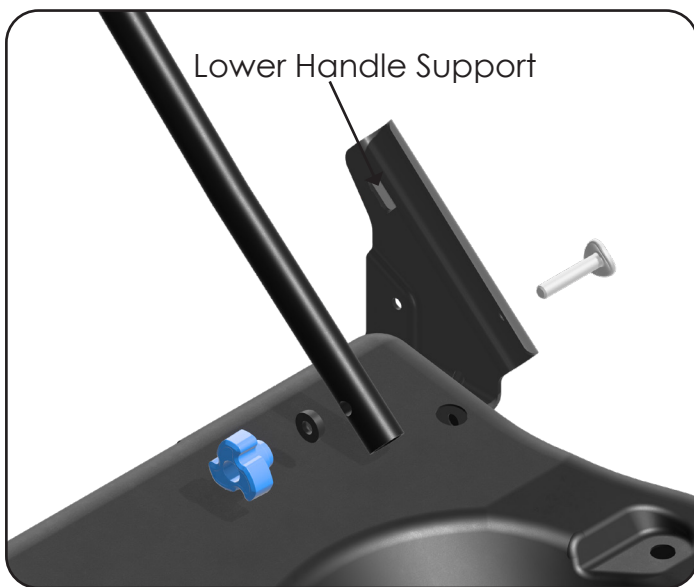

Assembly

Handle Assembly (Continued)

Step 2 : Assemble the Upper handle

The Upper handles use a bolt and a hand nut. Place the large bolt through hole at the top of lower handles.

Manoeuvre the holes in the upper handle into position to place the bolts through. Secure either side with the hand nuts as shown below.



Step 3 : Accessory Tray

Attach the accessory tray to the upper handles. Place the tray into position and secure with 4 bolts.

Step 4 : Connect Battery

Put the 2 battery connection terminals together

Step 5 : Charge Battery

Remove the battery from the cradle and charge it for at least 6 hours

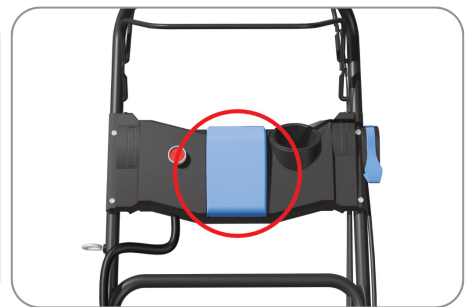

Assembly

Grass Collection box Assembly

Clip the U-shape plastic channel clips over the frame of the Grass collection box. There's 1 either side and larger clip on the bottom.



Mulching Plug

The mulching plug is used when you would like your grass clipping to be left on the lawn. The clippings act as a feed for your grass.

To remove the mulching plug, squeeze the handle of it to disengage the securing mechanism and pull. To replace the plug squeeze the handle and insert. Give the plug a pull to ensure the mechanism is engaged correctly.

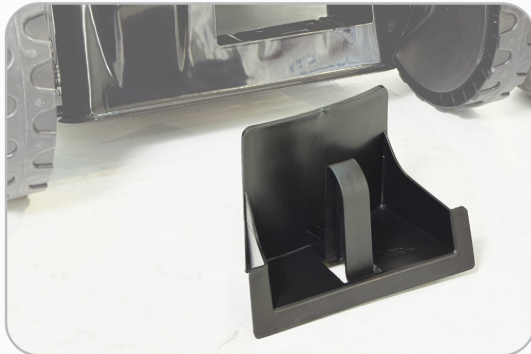

Side discharge chute

The side discharge chute is used when you don't want to collect the clippings, but the grass is too long for the needs of mulching. The discharge side discharge chute will allow for easier raking in the future.

The chute just clips on to the side of the mower deck. Lift the silver clip on side discharge cover and lift. Mount the chute into the 2 prongs and lower the cover.



Pre-Operation Checks

Checking Oil Level

⚠ WARNING! THIS MACHINE IS SHIPPED WITHOUT ANY OIL. YOU MUST FILL THE MACHINE WITH OIL BEFORE STARTING IT FOR THE FIRST TIME.

WARNING: The following checks and procedures are essential to prevent any damage and operational damage to your machine. You MUST follow them.

Recommended Oil: Always use high quality SAE30 oil (or equivalent e. g SAE 10W/30, often termed as 4 Stroke lawn mower oil). Never use additives with recommended oil. To prolong the life of your engine it is important that the oil is changed after the first 5 hours of use. After this, follow the instructions in the maintenance section of the manual.

Step 1 : Stop the machine on level ground. If your machine is sat on a slope, you will get inaccurate readings.

Step 2: Remove the oil filler dipstick and wipe the oil from it with a clean cloth.

Step 3: Insert the dipstick into the oil filler neck, but do not turn it in.

Step 4 : Then remove the dipstick and check the oil Level. The oil level must be between the Min and Max marks on the dipstick. If near the lower level ,fill to upper level with the recommended oil(SAE30 or equivalent). Do not overfill. Wipe away any spilt oil.)

Step 5 : Align the ribs of the cap with the groove of the filler neck . then rotate 1/4 turn to secure it.



Pre-Operation Checks

Filling with Fuel

⚠ NOTE: Always use clean, fresh E5 or E10 unleaded petrol. Only ever fill with enough fuel which can be used within 30 days. Fuel can go stale over 30 days old which will cause issues with the machines operation.

⚠ WARNING: This is a 4-stroke machine. There is no need to mix oil into the fuel

⚠ WARNING: Petrol is highly flammable and extreme precaution must be taken when handling or working with it.

⚠ WARNING! THIS MACHINE IS SHIPPED WITHOUT ANY OIL. YOU MUST FILL THE MACHINE WITH OIL BEFORE STARTING IT FOR THE FIRST TIME.

1. Clean the area around the petrol filler cap before removing the cap. Remove the warning tag, check the fuel level.
2. Refill the tank if the fuel level is low. (First time starting the machine, the fuel tank will be empty)
3. Refuel carefully to avoid overfilling or spilling fuel. There should be no fuel in the filler neck.
4. Clean up any overflow or splashes of petrol before starting the engine.
5. Tighten the filler cap after filling, finger tight on.



Operation

Cutting Height Adjustment

⚠ WARNING! Only adjust the cutting of the machine when the machine is off, and all moving parts have stopped.

The cutting height is centrally adjusted with cutting height adjusting handle. Different cutting heights can be selected.

Pull the adjusting handle out and select the desired cutting height. The handle snaps into the desired position.

This machine has 7 cutting heights from 25mm to 75mm

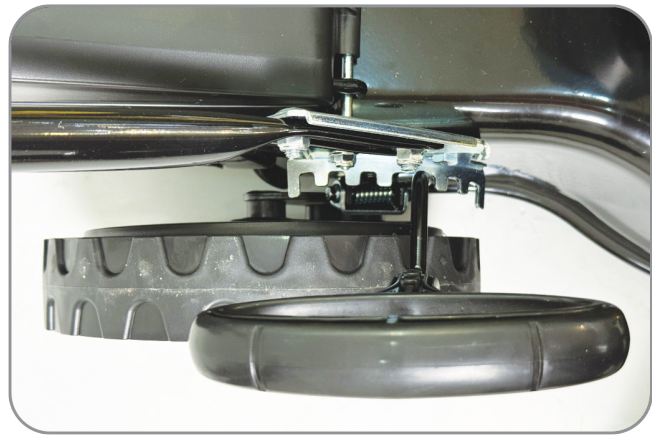

Charge Battery

To use the E-start function you must ensure the battery is charged before use. To charge the battery, put the charger into a suitable outlet and connect the wire into the battery charging port.

Then turn on your power outlet, the battery should charge from empty to full within an hour.

Operation

Starting and Stopping

⚠ WARNING : The blade will rotate as soon as the engine is started.

⚠ WARNING: Only operate the machine in well ventilated areas

⚠ WARNING : Keep all body parts and clothing away from the moving parts of the machine. Contact with these parts will cause harm and damage. This also applies to the exhaust and other hot areas of the machine.

⚠ To start the machine, ensure the machine is filled with oil and petrol, and the spark-plug is connected.

Starting with E-Start

Step 1 : When starting, pull the Choke Lever to the "START" position.

Step 2 : Stand behind the mower . Pull the engine OPC lever toward the upper handle with one hand . Then with the other hand, turn the E-start key.

Step 3 : After the engine has run for a few seconds, move the Choke Lever toward the "RUN" position.

⚠ NOTE : If the engine fails to start after 10 seconds, repeat the process . Only repeat 3 times. If the machine fails to start try the manual method with the recoil starter.

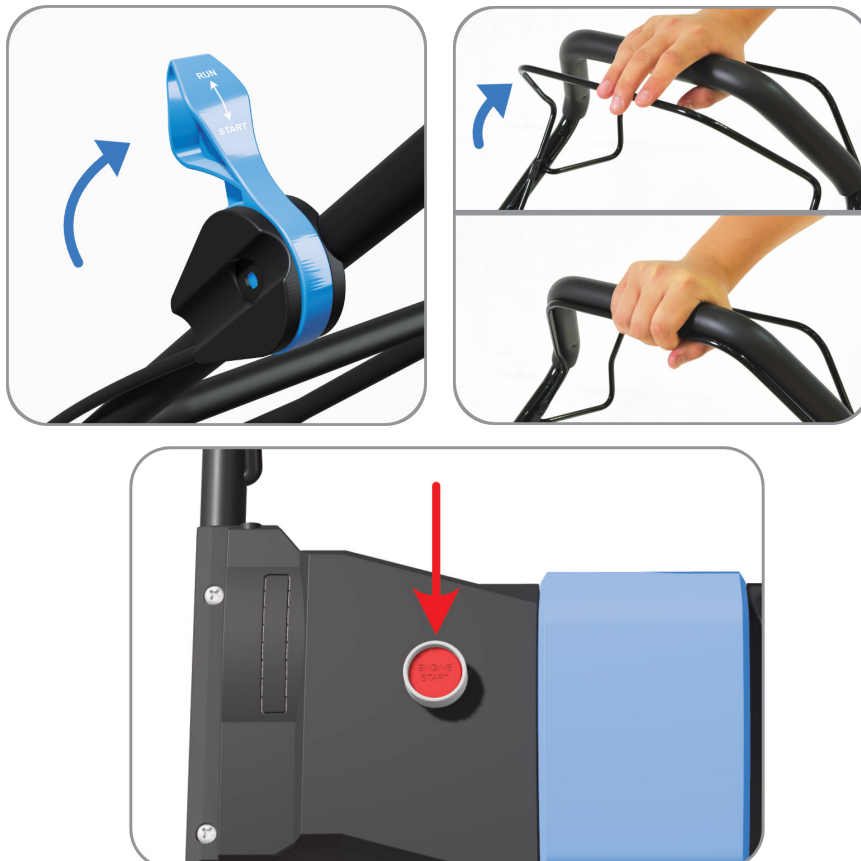

Operation

Starting with Recoil

Step 1 : When starting, pull the Choke Lever to the "START" position.

Step 2 : Stand behind the mower . Pull the engine OPC lever toward the upper handle With one hand . And Place the other hand on the recoil starter (pull start on the engine).

Step 3 : Pull the recoil starter approx. 10-15cm Until you feel a resistance and then start the Engine with a sharp pull .When the engine starts, allow the recoil to return.

Step 4 : After the engine has run for a few seconds, move the Choke Lever toward the "RUN" position.

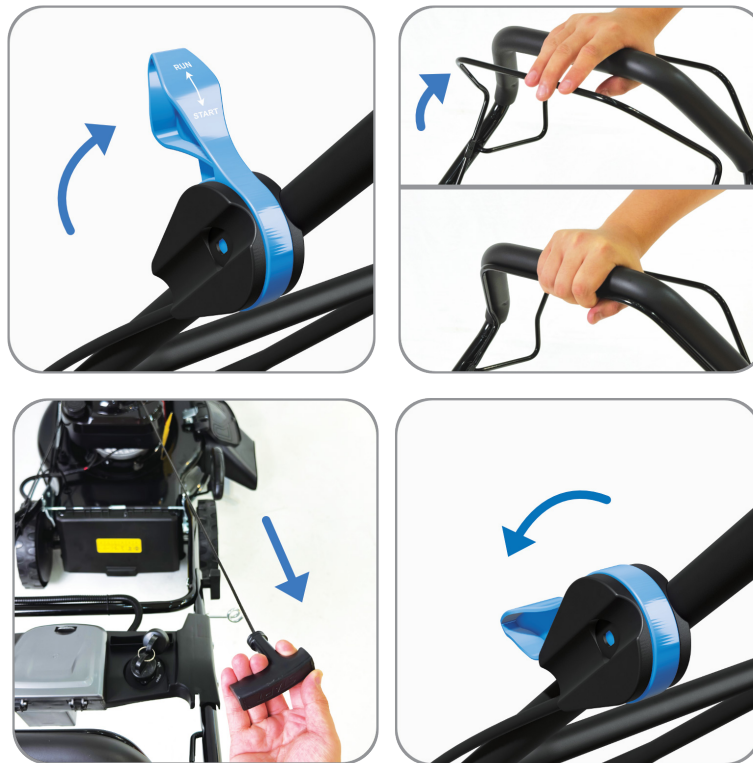

Stopping

To stop the engine, simply release the OPC lever. This should instantly stop the engine.

Solving a "Flooded Engine"

⚠️ NOTE: if the engine won't start after you have Operated the starter several times , the engine may be flooded with excess fuel . Use following procedure to clear and start a flooded engine.

Step 1 : Ensure all moving parts have stopped and the machine has cooled down.

Step 2 : Remove the spark plug from the engine.

Step 3 : Dry and clean the spark plug, and reinstall carefully by hand first. This is to avoid cross threading the threads.

Operation

Self Propulsion

⚠ WARNING : Ensure before operating the working area is clear of any obstacles or persons whom may cause hazard.

⚠ WARNING : When finished with the machine, pull the Choke Lever back in the “START” position.

Step 1 : Ensure the Choke Lever is fully pressed forward into the “RUN” position. If you try to operate the machine with it in the “START” position it will likely stall the engine and cut out.

Step 2 : With the engine running and holding the OPC lever, pull the drive lever toward the main handle.

Note: The drive lever operates the engagement of a drive gear and will propel your mower forwards , This lever should be either fully pulled or fully released , feathering of the lever and trying to use it as a clutch such as in a motor vehicle will result in undue wear and damage to the drive gearbox



Lawn Care

General Mowing Tips

- Maintain a constant cutting height. Do not shorten the grass to less than half its original height.
- Under certain conditions, such as very tall grass, it may be necessary to raise the height of cut to reduce pushing effort, prevent overloading of the motor and leaving clumps of grass clippings.
- It may also be necessary to reduce ground speed and/or push the lawnmower over the area a second time. For extremely heavy cutting, reduce the width of cut by overlapping the previously cut path and mow slowly

How Often Should I mow?

Spring (March, April & May)

Mow once a week on a high to medium height setting.

Summer (June, July & August)

Mow twice a week under good growing conditions on a low setting. In dry conditions, mow once a week on a medium to high height setting.

Autumn (September, October & November)



Mow once a week on a medium height setting.

Winter (December, January & February)

Mow as required on a high height setting.

Replacement Parts & Spares Info

POWER SPARES

 No hassle returns  Over 10,000 spare parts  Same day dispatch*



QR Code – Scan the QR code for a direct link to our website

Our Website : power-spares.co.uk

Call us : 01646 404406

Email us : sales@power-spares.co.uk

To maintain your machine in peak operating condition, proper maintenance and care are crucial. Some machines have consumable parts that will need replacement to ensure they continue operating at their full potential. Power-Spares provide manufacturer parts for all your machines, ensuring they remain in peak condition.

General Cleaning

Power-Spares has your back if you damage your lawn mower blade, find your spark plugs not sparking, or snap your recoil. Power-Spares operates under the trading name of Genpower Limited.

As part of the Genpower family, Power-Spares offers you the expertise, efficiency, and quality assurance of a large organisation. We leverage the latest warehousing, distribution, customer service, and inventory management technology to ensure you receive your parts as quickly as possible.

With extensive stock-holding of spare parts in our UK warehouses, Power-Spares is ready to assist you promptly when your machine needs repair. We're Committed to help you get back up and running as quickly as possible.

Maintenance & Care

General Maintenance

⚠ WARNING : Turn OFF the machine, allow all moving parts to come to a complete stop, and disconnect the power cord before maintaining the machine. You need to wear proper clothing and protective gloves whenever your hands are at risk.

- Keep all nuts, bolts and screws tight to be sure the machine is in a safe working condition.
- Replace worn or damaged parts for safety. Only use manufacturer-recommended parts and accessories.
- Lubricate the wheels every 100 hours
- Periodically check the wires around the machines for damage and loose connections.
- Always check the brakes of the machines are working correctly
- Regularly examine the batteries, ensure they are clean and dry.
- Always charge your batteries to full charge before use

Storage

- Keep the machine stored in a dry, level area away from damp, moisture and rain fall. Allow the machine to cool down before storing.
- Make sure the machine is clean and dry before storing.
- Ensure the machine is stored in a position, where any persons cannot step on, to attempt to reach items up high, due to risk of movement.
- DO NOT store the machine near an ignition source, such as a wood stove, gas or electric heater, or an appliance or heater with a pilot light.
- Store the machine out of reach of children or anyone who is not familiar with operation.
- DO NOT stack other items on top of the machine when in storage.
- Make sure the machine is stored away from direct sunlight. Store indoors or in a safe, frost-free area during severe weather and winter months.

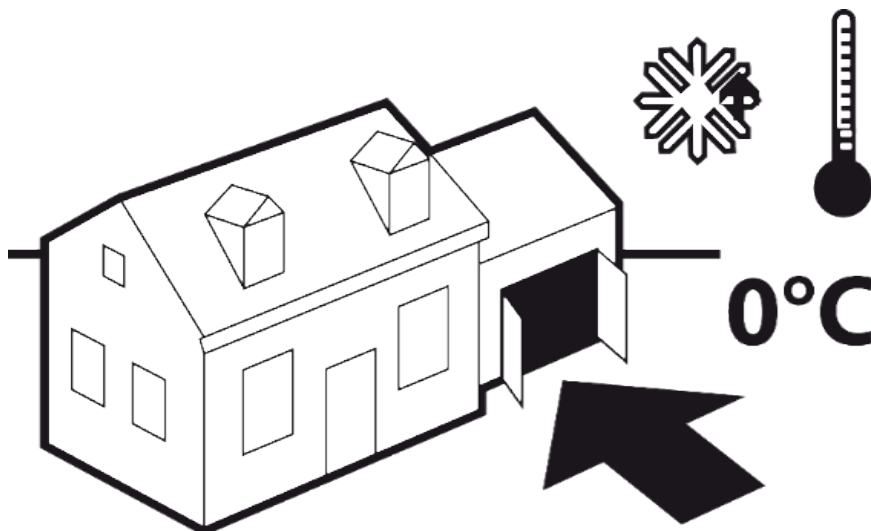

Maintenance & Care

Maintenance Schedule

Performing routine maintenance correctly on your lawnmower will ensure you get years of trouble free use.

Please keep this manual safe for future reference.

It is recommended that the following maintenance schedule is adhered to. This will ensure the lawn-mower operated correctly and is safe to use.

	After 12 Hours	After 24 Hours	After 36 Hours
Air Filter	Clean	Clean	Replace
Spark Plug	Check	Clean	Replace
Engine Oil	Check	Replace	Check

Long Term Storage

If storing the machine for a period of 30 days or more, you must follow proper storage and winterisation guidelines to avoid any possible issues with the machine. Incorrect storage can lead to possible fueling or engine issues that will not be covered by the warranty.

Allow the engine to fully cool down.

1. Drain all the fuel from the fuel tank and then run the machine until it has completely run out of fuel to clear the remaining fuel from the fuel lines and carburettor.
2. Drain the oil from the engine.
3. Follow the cleaning instructions in the 'Cleaning' section.
4. Follow the maintenance section and check, service or replace serviceable items if required. Visually inspect the machine and replace or repair any worn parts. Check the blade and sharpen or replace if necessary.
5. Lubricate all moving parts with light spray oil such as WD40.
6. Refill engine oil with new SAE 30 or 15w40 engine oil, fill to the upper mark on the dipstick.
- 7 Remove the spark plug and pour 1 teaspoon of fresh engine oil down the cylinder bore. Cover the spark plug hole with a lint free clean cloth, ensuring no dirt or debris falls into the cylinder chamber and gently pull the recoil starter handle to coat the cylinder bore with the fresh oil.
Refit the spark plug.

Preparation to re-use after storage

1. Check oil level before using.
2. Check spark plug is inserted correctly.
3. Fill engine with fresh unleaded petrol that has not been stored for periods of more than 30 days.

Maintenance & Care

Cleaning the Mower Blade

⚠ WARNING : If the mower blade and Rotor is left unclean and clogged with grass, this will affect the efficiency of the mower.

⚠ WARNING : Fuel may leak from the machine whilst performing this maintenance. To avoid this completely, drain the machine of all fuel.

- Starting from the rear of the machine, turn the machine onto its right hand side.
- Start by removing all obvious large clumps of grass stuck to the edges of the mower deck, Blade and Rotor
- Using water at normal hosepipe pressure, you can rinse all hard to reach areas on the inderside of the mower.

Blade Replacement

⚠ WARNING : NEVER fully invert or turn the mower over completely when it's full of oil and fuel. You can tilt the mower slightly on the side of the oil filler to inspect the blade. IF the blade needs replacement drain the oil and fuel to proceed.

⚠ WARNING : Wear protective gloves when handling the mower and blade.

⚠ WARNING : Sharpening and balancing of the blade should only ever be carried out by qualified and trained personnel

1. The blade is made of pressed steel, in order to obtain a good cut, sharpen the blade frequently, typically around every 25 hours of work.
2. Following blade sharpening, you must make sure that the blade is always well balanced.
3. To remove the blade, unscrew the centre bolt, check the blade carrier and all components. Replace if they are worn or damaged.
4. Blade maintenance can be at our specialised centre that has the special tools and equipment.
5. Only original blades must be used on this machine. Given product evolution, the blades may be replaced in time with others having similar interchangeable and operating safety features.

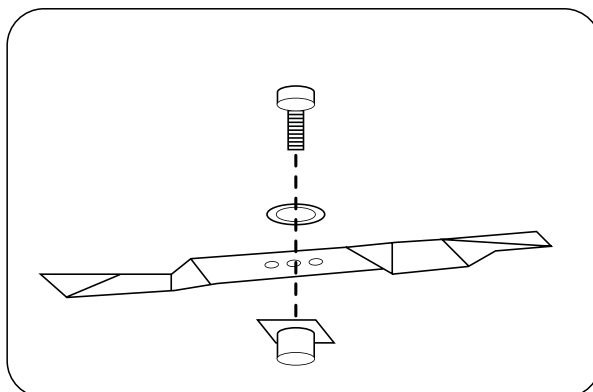

Maintenance & Care

Air Filter Maintenance

⚠ WARNING!: Never operate the machine without an air filter. Operating without one can cause small particles and debris to be ingested into the engine and possibly cause damage.

1. Remove the air cleaner outside cover. Be careful to prevent dirt and debris from falling into the air cleaner assembly.
2. Separate the Air Filter from the Air Filter Housing .
3. Inspect the air filter. Clean dirty air filter with warm water and mild soap. Allow air filter to dry thoroughly before re-installation
4. Install the air filter assembly onto the carburetor and secure with screw.

Note: Do not use pressurized air or solvents to clean the filter. Pressurized air can damage the filter and solvents will dissolve the filter.

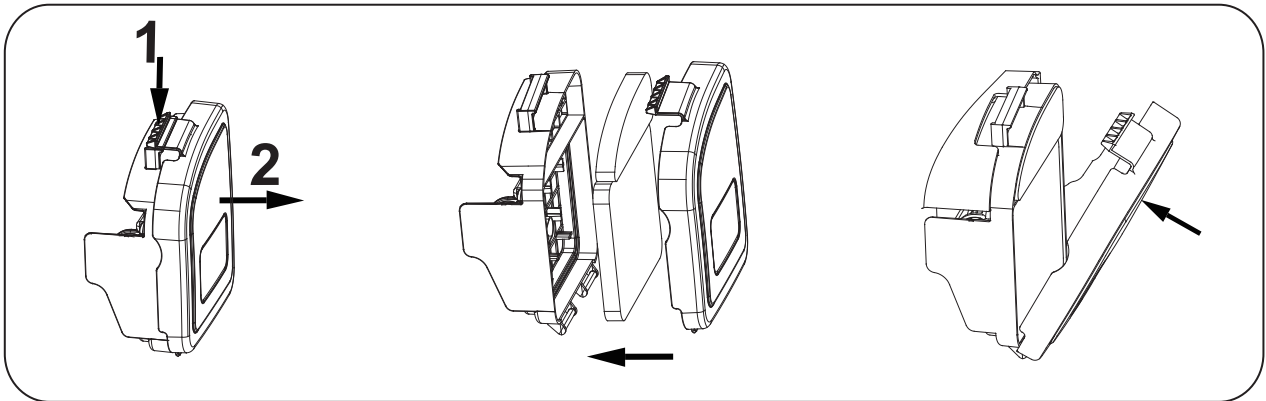

Changing Engine Oil

Tilt the lawnmower towards the oil filler , have a container ready to catch the oil and remove the dipstick .

once the oil has been emptied , replace the dipstick and wipe clean any spillages.

Refill with 400ml SAE30 oil or equivalent i. e SAE5W/30, SAE10W/30.

When the dipstick is inserted back (without turning back in), the oil level must be between the min and max marks on the dipstick.

Start the engine and allow it to run briefly.

Stop the engine ,wait one minute and check the oil level . top up if necessary .

Maintenance & Care

Spark Plug Maintenance

For good performance, the spark plug must be properly gapped and free of deposits. You **MUST** allow the engine to cool down before carrying out any maintenance.

1. Always use the correct spark plug.
2. To check the spark plug, remove the spark plug HT lead cap and remove the spark plug with the spark plug wrench.
3. Remove spark plug using the supplied spark plug wrench.
4. Clean the spark plug electrode with a soft wire brush, making sure there is no damage to the insulator or electrode.
5. The spark plug gap should be 0.70mm to 0.80mm. Check the gap by using a feeler gauge.

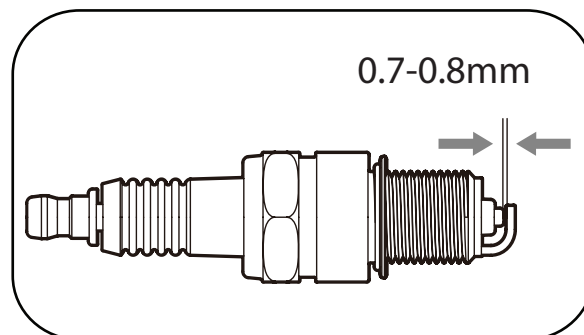

Troubleshooting

⚠ Faults which cannot be rectified with the aid of following table may be rectified by a qualified technician (contact our customer service team to arrange). Please be aware that any improper repairs will also invalidate the warranty and additional costs may be incurred. Use only genuine spare parts. Only these spare parts are designed and suitable for the product. The use of other spare parts not only voids the warranty, you can also endanger yourself and your environment.

Symptom(s)	Possible Cause(s)	Corrective Action(s)
Loud while running, Makes a weird noise, Machine Vibrates	Screws are loose	Check and tighten screws
	Blade fasteners are loose	Check blade fasteners
	Blade is unbalanced	Replace blade
Engine does not start	OPC lever not pressed	Press OPC lever whilst starting
	Spark plug is defective	Replace spark plug
	Does the cutting blade is worn or damaged ?	Replace it by the customer service center
	Fuel tank is empty	Refill with fuel
	Engine may be flooded	Remove plug and dry
Engine doesn't run well	Air filter is dirty	Clean the air filter
	Spark plug is dirty	Clean the spark plug
Uneven Mowing Results	Blade is blunt	Sharpen the blade
	Cutting height is too low	Set correct heightfor grass length
Grass bag doesn't fill/ Grass is no longer being collected	Blade is worn	Replace the blade
	Grass bag full	Empty Grass bag
	Lawn/Work area is wet	Stop use and allow lawn/work area to dry
	Outlet Chute blocked	Stop machine, allow to cool and remove any blockages
	Mower deck is clogged with dirt/ clippings	Stop machine, allow to cool and remove any residue on the deck

Contact

Need Help? Talk To Our Experts

Our friendly aftersales team will be more than happy to help you



Phone

Call our team on 01646 687 880



Email

aftersales@hyundaipowerproducts.co.uk



Online Live Chat

Go to www.hyundaipowerproducts.co.uk



Post

Genpower Ltd, Isaac Way, Pembroke Dock, Pembrokeshire, SA72 4RW.



Hyundai Support Website

Go to hyundaisupport.co.uk

Recycling & Disposal

WEEE Information



We do not offer a takeback scheme for the recovery of Waste Electrical Electronic Equipment (WEEE) & Batteries. Instead the responsibility to dispose of WEEE and/or Batteries is passed onto you by us.

So when it becomes necessary to dispose of your machine you must take it to your local Civic Amenity Site. For further information please contact your local Authority for disposal advice.

You MUST make sure that all unused oil and fuel is disposed of correctly either beforehand or at your local Civic Amenity Site.

- Under NO circumstances must any fuel or oil be put down any drains.
- Certain products contain WEEE waste which should not be disposed of in your domestic waste.
- You MUST recycle WEEE in accordance with your local authority or recycling centre.
- Certain products contain batteries which should not be disposed of in your domestic waste.
- You MUST recycle batteries in accordance with your local authority or recycling centre.
- Unwanted packaging and materials should be stored and taken to a recycling centre so it can be disposed of in a manner which is compatible with the environment.

We are a Member of the VALPAK National Compliance Scheme and our registration number is RM08660. For further information about disposal please contact your Local Authority.

You can also get more advice and guidance about recycling at the following website <http://www.recycle-more.co.uk>

Should you pass this product on to another user either sold or loaned, you MUST pass on this user manual. This will make sure that all other users can use and maintain this machine safely.

Environmental Protection

1. Environmental protection should be a priority of considerable importance when using the machine, for the benefit of both social coexistence and the environment in which we live. Try not to cause any disturbance to the surrounding area.
2. You must comply with local regulations and provisions for the disposal of packaging, oils, petrol, filters, damaged parts or any elements which have a strong impact on the environment. This waste must not be disposed of as normal waste. It needs to be separated and taken to specified waste disposal centres where the material will be recycled.
3. You must comply with local regulations for the disposal of waste materials after mowing.
4. When disposing, do not pollute the environment with the machine, but hand it over to a disposal centre, in accordance with the local laws in force.

Technical Data

Specification Table

Model	HYM20200SPEX
Start Method	Recoil and Electric with Auto Choke
Propulsion	Self-Propelled
Cutting Width (mm)	506
Cutting Height Min (mm)	25
Cutting Height Max (mm)	75
Cutting Positions	7
Cut Options	Side Discharge, Rear Bagging, Rear Discharge, Mulching
Catcher Volume (L)	60
Catcher Type	Half Plastic With Polyester Bag
Handle Type	Soft Grip
Safety Features	Operator Presence Control
Deck Material	Steel
Quick Clean Hose Connector	Yes
Engine Model	TB1P70FBE
Engine Type	4-Stroke OHV Single Cylinder
Engine Size (cc)	196
Power (hp)	5.5
Fuel	Unleaded Petrol
Fuel Capacity (L)	1.5
Engine Oil	SAE 10W-30
Engine Oil Capacity (ml)	600
Gross Weight (kg)	40
Net Weight (kg)	37
Wheel Diameter (mm)	Front: 203, Rear: 254
Fully Assembled Dimensions (H x W x L) (mm)	1460*670*1040
Package Dimensions (H x W x L) (mm)	830*570*490
Fuel/Power Source	Petrol
Guaranteed Sound Level LWA (db(A))	97
Uncertainty KwA (db(A))	0.69
Vibration Level values (m/s ²)	Left 3,011 / Right 3,024 m/s ²
Uncertainty K (m/s ²)	1.5

Declaration of Conformity

Importer and Authorised Representative

Genpower Ltd
Isaac Way, Pembroke Dock, SA72 4RW
Country of Origin: China
Description: 506mm Self Propelled Electric Start Petrol Lawn Mower
SKU Code: HYM20200SPEX
Date of Issue: 01/12/2025

Regulations and Directives of Compliance

- 2014/30/EU The Electromagnetic Compatibility Directive
- 2006/42/EC The Machinery Directive
- 200/14/EC Noise emission in the environment by equipment for use outdoors
- 2011/65/EU The Restriction of Hazardous Substances Directive
- 1907/2006 REACH EC No 1907/2006 - SVHC
- 1907/2006 REACH Regulation (EC) No 1907/2006 Annex XVII
- Regulation (EU) 2016/1628 gaseous and particulate pollutant emission limits for internal combustion engines.
- 2023/1542 (EU) Battery Regulation

And is in conformity with the applicable requirements of the following documents:

EN ISO 14982:2009	EN 60335-2-29
EN ISO 5395-1:2013+A1:2018	EN IEC 55014-1
EN ISO 5395-2:2013+A1:2016+A2:2017	EN IEC 55014-2
BS 1363-1	EN IEC 61000-3-2
IEC 62133-2:2017	EN 61000-3-3
EN 60335-1	

Statement of Declaration

We the importer and authorised representative of the product described confirm conformity within the provisions of applicable regulations and directives listed within this document.

Signed on Behalf of Genpower Ltd

Identification of Manufacturer:

Genpower Ltd, Isaac Way, Pembroke Dock, Pembrokeshire, SA72 4RW, UK.

Name and address of technical documentation holder and EU distributor:

Genpower Ltd, 131 Boulevard Pereire, 75017 Paris, France.

Place of Issue: Genpower Ltd

Signatory Name: Roland Llewellyn

Position: Managing Director

RJLlewellyn



Useful Information

Check Out Our YouTube Channel

Our videos on YouTube include:

- Unboxing
- Assembly of your machine
- How to service your machine
- Products in use
- 'How To' videos
- Product features

Go to YouTube and search 'Hyundai Power Products'.

Warranty

Proof of purchase will be required before you make a warranty claim. Full warranty terms and conditions can be found on the HYUNDAI POWER PRODUCTS website: www.hyundaipowerproducts.co.uk

Manual Updates

Our manuals are constantly being reviewed and updated. Should you find an error, omission or something unclear, please contact us for assistance. We reserve the right to make any modifications without prior notice whenever necessary.

Our latest manuals are also placed online. All our manuals can be downloaded at: www.hyundaipowerproducts.co.uk

Returning Your Product

If you are returning your product, please contact the dealer for their returns policy.

Leaving A Review

We work very hard to give all of our customers the best possible service. If you have any problems, before leaving negative feedback, please contact us to give us a chance to resolve the issue. We would be delighted if you left us positive feedback! To leave a review, please go to: uk.trustpilot.com/review/hyundaipowerequipment.co.uk

Ordering Spare Parts

You can find the spare part you are looking for at power-spare.co.uk

Product Record

Information

As soon as you have purchased the machine, we recommend that you fill out the following. If you need to contact an authorised dealer or customer service for information on servicing, you may need to provide the following information.

Date Of Purchase:.....

Dealer Name:.....

Dealer Phone:.....

Model Number:.....

Serial/Batch Number:.....

HYUNDAI

POWER PRODUCTS



GENUINE PRODUCT OF
HYUNDAI CORPORATION

For Inquiries, Please Contact:
GENPOWER LTD
Isaac Way, London Road,
Pembroke Dock, UK, SA72 4RW.
T: +44 (0) 1646 687 880
E: info@hyundaipowerproducts.co.uk
www.hyundaipowerproducts.co.uk

Imported / Distributed by Genpower Ltd for
the United Kingdom & Ireland

Licensed by Hyundai Corporation Holdings, Korea